



STYLE



-SINCE 1918-



KOLARZ Zentrale Breitenfurt b. Wien, Österreich | KOLARZ Head Office Vienna, Austria



Logistikzentrum Müllendorf, Österreich | Logistics Center Müllendorf, Austria

 **KOLARZ GmbH**
 Hauptstraße 103
 2384 Breitenfurt b. Wien
 Austria
 ☎ Tel.: +43 2239 2721
 📠 Fax: +43 2239 3983
 ✉ e-mail: office@kolarz.at
 🌐 www.kolarz.at

 **KOLARZ LOGISTICS CENTER**
 Industriestraße V1
 7052 Müllendorf
 Austria

 **KAPPA LUCE SRL**
 Italy
 ☎ Tel.: +39 392 662 05 66
 ✉ e-mail: export@kappaluce.it
 🌐 www.kappaluce.it

 **KOLARZ LTD**
 United Kingdom
 ☎ Tel.: +44 1483 726 052
 ✉ e-mail: info@kolarz-uk.com
 🌐 www.kolarz-uk.com

 **KOLARZ BUDAPEST KFT**
 Hungary
 ☎ Tel.: +36 309 560 454
 📠 Fax: +43 2239 2721
 ✉ e-mail: info@kolarz.hu
 🌐 www.kolarz.hu

 **KOLARZ PRAGUE SRO**
 Czech Republic
 ☎ Tel.: +420 222 72 4510
 ✉ e-mail: office.cz@kolarz.com
 🌐 www.kolarz.cz

 **KOLARZ ROMANIA SRL**
 Romania
 ☎ Tel.: +40 21 315 14 88
 ✉ e-mail: office.ro@kolarz.com
 🌐 www.kolarz.at

 **KOLARZ OFFICE SHANGHAI**
 China
 ☎ Tel.: +86 21 55 88 62 68
 ✉ e-mail: c.lu@kolarz.at
 🌐 www.kolarz.at

 **KOLARZ OFFICE MOSCOW**
 Russia
 ☎ Tel.: +7 495 142 89 52
 ✉ e-mail: t.korkishko@kolarz.at
 🌐 www.kolarz.at

 **KOLARZ EAST EUROPE**
 Armenia, Azerbaijan, Belarus,
 Estonia, Georgie, Kazakhstan,
 Kyrgyzstan, Latvia, Lithuania,
 Moldova, Tajikistan, Turkmenistan,
 Ukraine, Uzbekistan
 ☎ Tel.: +380 67 508 86 53
 ✉ e-mail: v.nakonechnyi@kolarz.at
 🌐 www.kolarz.at



INDEX



AMPOLLA 46



VIRGOLA 96



GIOIOSA 158

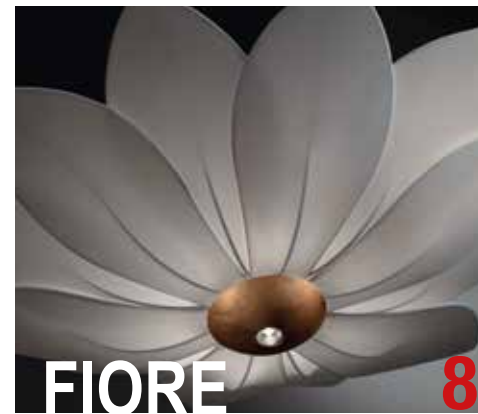

FIORE 8



MOBILE MURANO 2 56



PRISMA SLIM 104



NOBILE 168



TULIPANO 20



CLOUD 62



PRISMA 116



CARLA 178



VELA 28



SPADA 74



STRETTA 136



DELPHI 190



RIVIERA 36



FONTE DI LUCE 82



PARALUME 148

FIORE

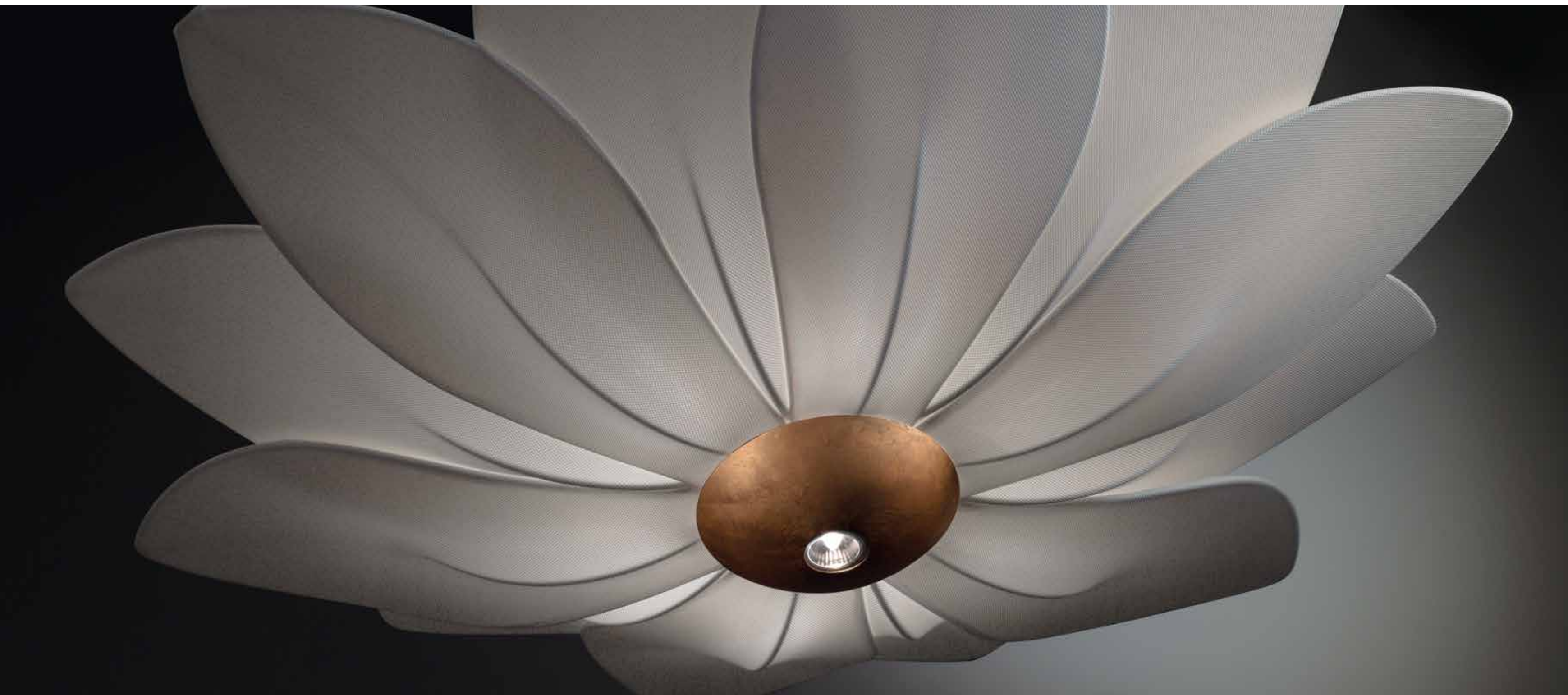

Design by Manuel Vivian





5231.80630



5231.80630

Blumen aus Licht: Manuel Vivians naturinspirierte Designsprache beeindruckt mit einem perfekten Mix aus Funktionalität und Fantasie. Blütenblätter aus weißem, waschbarem Stretch-Gewebe liefern helles, indirektes Licht. Optionale Spotlights sorgen für direkte, fokussierte Beleuchtung.

Flowers of light: Manuel Vivian's nature-inspired design vocabulary impresses with a perfect mix of functionalism and imagination. Bold petals made of white, washable stretch fabric provide bright indirect light. Optional spotlights offer direct, focused lighting.



5230.80610



5230.60650





FIORE

	1)	1)	1)	1)	
	☒ 120 cm ☒ 23 cm / max. 250 cm ☒ 6 lp., E27, 42 W + 1 lp., GU10, 50 W	☒ 82 cm ☒ 18 cm / max. 250 cm ☒ 6 lp., E27, 42 W + 1 lp., GU10, 50 W	☒ 120 cm ☒ 25 cm ☒ 6 lp., E27, 42 W	☒ 82 cm ☒ 20 cm ☒ 6 lp., E27, 42 W	
	white	5230.80610	5231.80610	5230.60610	5231.60610
	gold leaf	5230.80630	5231.80630	5230.60630	5231.60630
	silver leaf	5230.80650	5231.80650	5230.60650	5231.60650

	1)	1)	2)3) LED	
	☒ 30 / 44 cm ☒ 21 cm ☒ 3 lp., E14, 42 W	☒ 17 cm ☒ 35 cm ☒ 1 lp., E14, 42 W	☒ 25 cm ☒ 155 cm ☒ 1 lp., 17,5 W, 1140 lm, 2700 K dimmable	
	white	5230.60310	5230.70110	5230.40410
	gold leaf	5230.60330	5230.70130	5230.40430
	silver leaf	5230.60350	5230.70150	5230.40450

Rosette



TULIPANO



Design by Manuel Vivian



6001.30115.140



6001.30115.140

Tulipano verzaubert mit floral-verspielter Formensprache by Manuel Vivian. Blütenblätter aus weißem, waschbarem Stretch-Textil strahlen luftige Leichtigkeit aus und harmonisieren in stylischem All-in-White-Look mit matt-weißem Metall. Glitzernder Hingucker: die funkelnden KOLARZ-Optic-Kristalle.

Tulipano shows a vivid floral shape designed by Manuel Vivian. The curved petals, made of washable stretch fabric, create an airy touch that harmonises with the matt-white metal for a stylish all-in-white look. Eye-catching detail: the sparkling KOLARZ Optic crystals.



6001.10615.140

6001.10314.140



6001.70615

6001.70314



TULIPANO

□ Frame: white Crystal: OPTIC® KOLARZ® Crystal Clear

	1) 				
white	6001.30115.140	6001.10615.140	6001.10314.140	6001.70615	6001.70314

Rosette



1) optional

- PUSH
- DALI
- 0-10 V
- LINEAR 100KΩ

VELA



Design by Manuel Vivian



6006.10654

6006.10655



6006.30655



6006.10695

6006.10634



6006.30694

Strahlend weißer, waschbarer Stretch-Stoff in maritimem Segeltuch-Look, von Hand veredelte Metallelemente in Matt-Weiß oder Blattgold-, Blattsilber- und Blattkupfer-Finish und dynamisch-frisches Design: Vela, designed by Manuel Vivian, sorgt für luftig-leichte Lichtblicke und sommerliches Flair.

Bright white, washable stretch fabric in a maritime canvas look, metal elements finished by hand in matt-white and brilliant gold, silver or copper leaf and a fresh dynamic design: Vela, a stunning eye-catcher designed by Manuel Vivian, adds lightness and style to any setting.



6006.10654

VELA

□ Frame: white



☑ 100 cm
☐ 12 cm / max. 200 cm
☑ 6 lp., E 27, LED, 13 W







☑ 70 cm
☐ 12 cm / max. 200 cm
☑ 6 lp., E 27, LED, 13 W



☑ 100 cm
☐ 12 cm
☑ 6 lp., E 27, LED, 13 W



☑ 70 cm
☐ 12 cm
☑ 6 lp., E 27, LED, 13 W

	white	6006.30615	6006.30614	6006.10615	6006.10614
	gold leaf	6006.30635	6006.30634	6006.10635	6006.10634
	silver leaf	6006.30655	6006.30654	6006.10655	6006.10654
	copper leaf	6006.30695	6006.30694	6006.10695	6006.10694

Rosette



RIVIERA

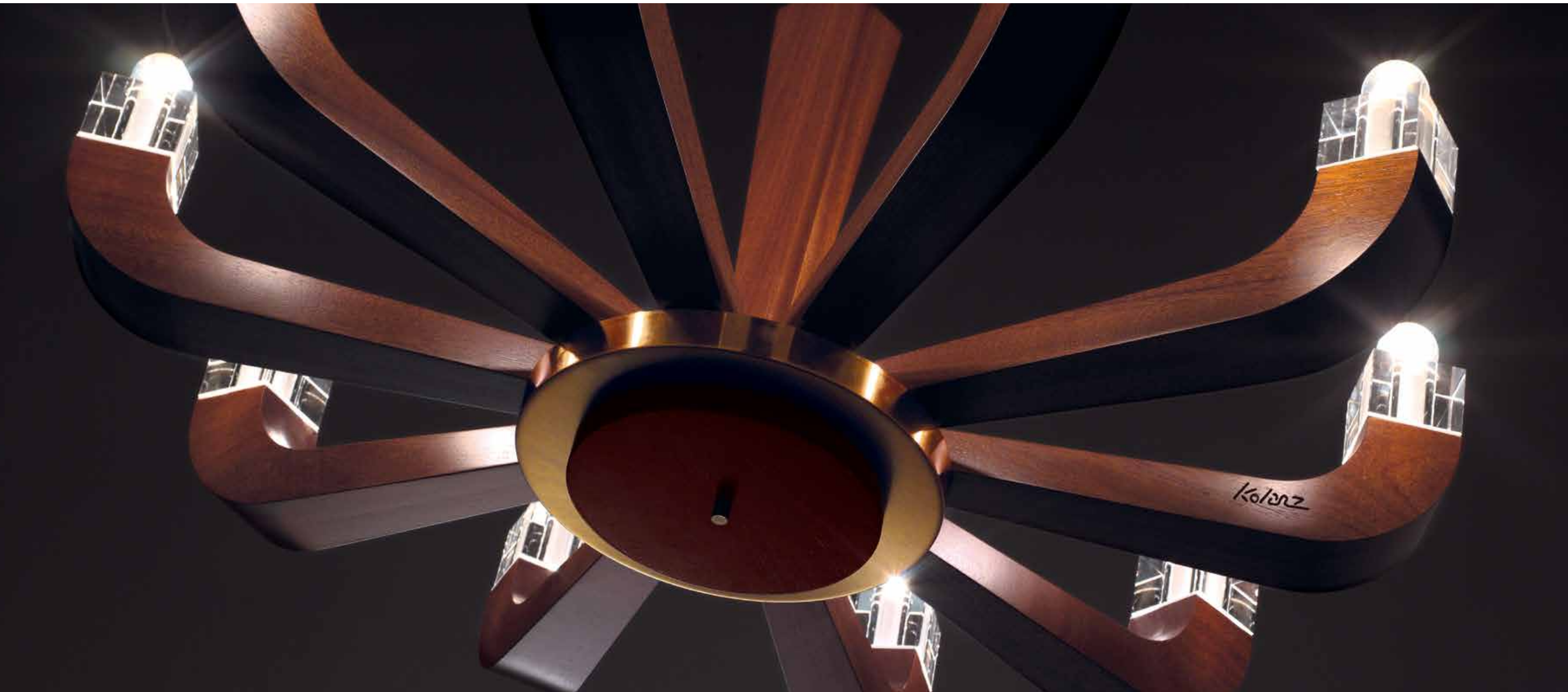

Design by Manuel Vivian



5202.80650



Dolce Vita trifft Art Déco: Manuel Vivians elegante Kreation kombiniert legendäre Kunststile des 20. Jahrhunderts mit modernem Style-Vokabular. Fließende Formen, chicer Monochrome-Look, stylische „naked bulbs“ und kunstvoll geschliffene Glaswürfel, die deren Licht reflektieren.

Dolce Vita meets Art Déco: Manuel Vivian's elegant creation combines iconic art styles of the 20th century with contemporary style vocabulary in a bold and brilliant light design. Flowing shapes, chic monochrome look, stylish naked bulbs and artfully cut glass cubes reflecting their light.





RIVIERA



5201.60230



5200.60150



Ø 100 cm
50 cm / max. 200 cm
10 lp., E14, 42 W



Ø 75 cm
50 cm / max. 200 cm
6 lp., E14, 42 W



7 / 7 cm
14 cm
1 lp., E14, 42 W



44 / 28 cm
25 cm
2 lp., E14, 42 W



12 / 12 cm
10 cm
1 lp., E14, 42 W



7 / 7 cm
9 cm
1 lp., E14, 42 W

	mahogany	-	-	5200.10100	-	-	5200.70100
	mahogany gold	5200.81030	5200.80630	-	5200.60230	5200.60130	-
	mahogany nickel	5200.81050	5200.80650	-	5200.60250	5200.60150	-
	white	-	-	5201.10100	-	-	5201.70100
	white gold	5201.81030	5201.80630	-	5201.60230	5201.60130	-
	white nickel	5201.81050	5201.80650	-	5201.60250	5201.60150	-
	black	-	-	5202.10100	-	-	5202.70100
	black gold	5202.81030	5202.80630	-	5202.60230	5202.60130	-
	black nickel	5202.81050	5202.80650	-	5202.60250	5202.60150	-

Rosette

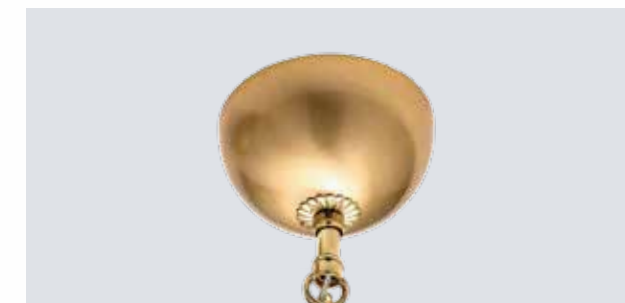

AMPOLLA



Design by Kolarz Studio





Stylisch-mondänes Design trifft funktionelle Beleuchtung: Ampolla setzt in jedem Setting ein starkes Style-Statement. Das von Hand gefertigte, gedrehte Glas, klar oder topa-sfarbig, zeigt dynamische Form, das fokussierte LED-Licht schafft atmosphärisches Ambiente.

Stylish, sophisticated design meets functional lighting: Ampolla makes a strong style statement in any setting. The handcrafted twisted glass, in a clear or fumée look, shows a dynamic shape, the focused LED light creates atmospheric ambiance.





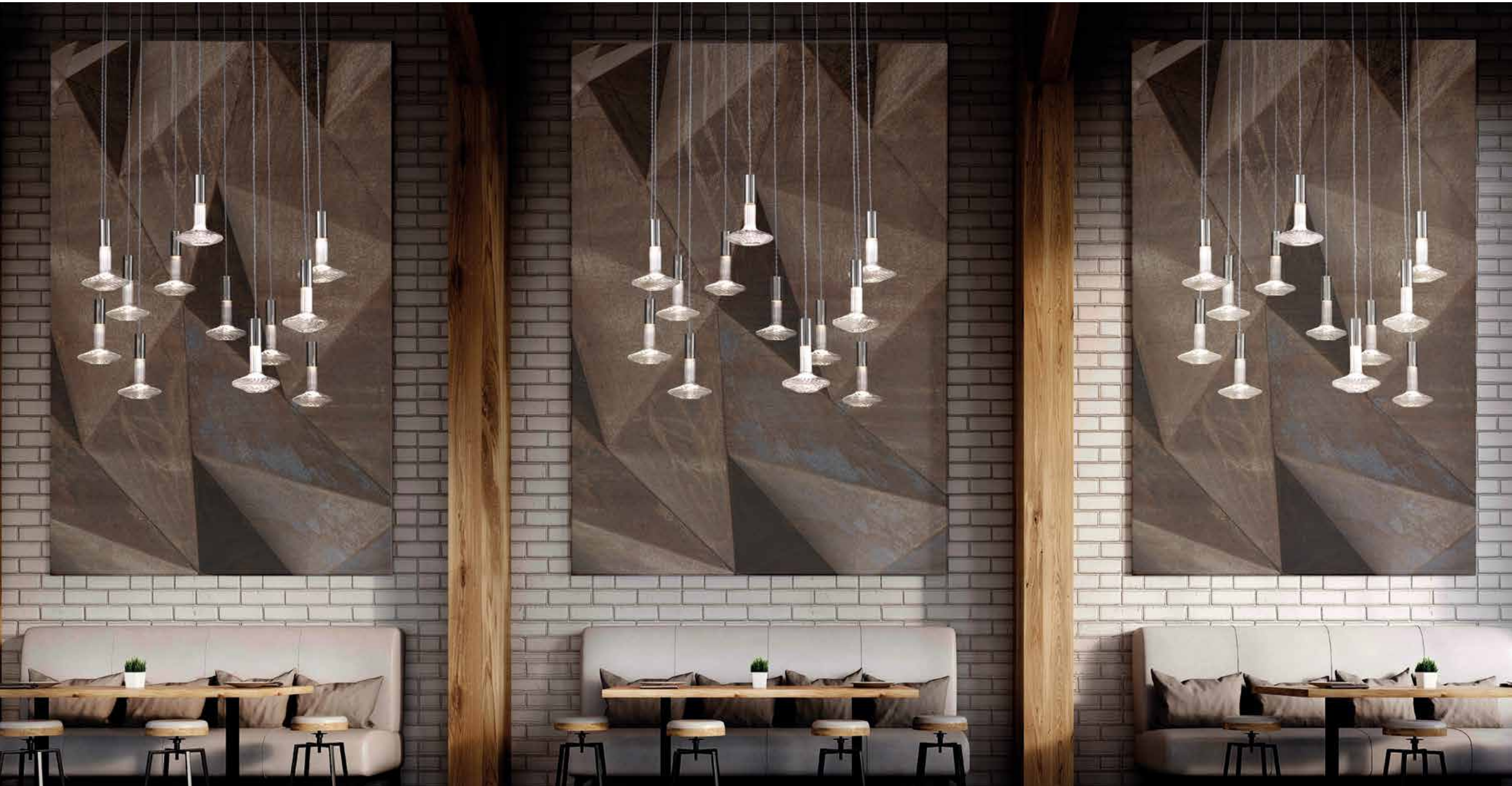

5200.70100

5200.70100



AMPOLLA

				
	Ø 50 - 150 cm 100 - 200 cm 12 lp., GU10 Mini	Ø 50 - 150 cm 100 - 200 cm 6 lp., GU10 Mini	Ø 12,5 cm 160 cm 1 lp., GU10 Mini	Ø 12,5 cm 160 cm 1 lp., GU10 Mini
 dark chrome	6007.31259.0	6007.30659.0	6007.30159.0	6007.60159.0



Decor

	
	Ø 20 cm 16 cm
 glass clear	6007.G01.T
 glass fumé	6007.G01.F



MOBILE MURANO 2

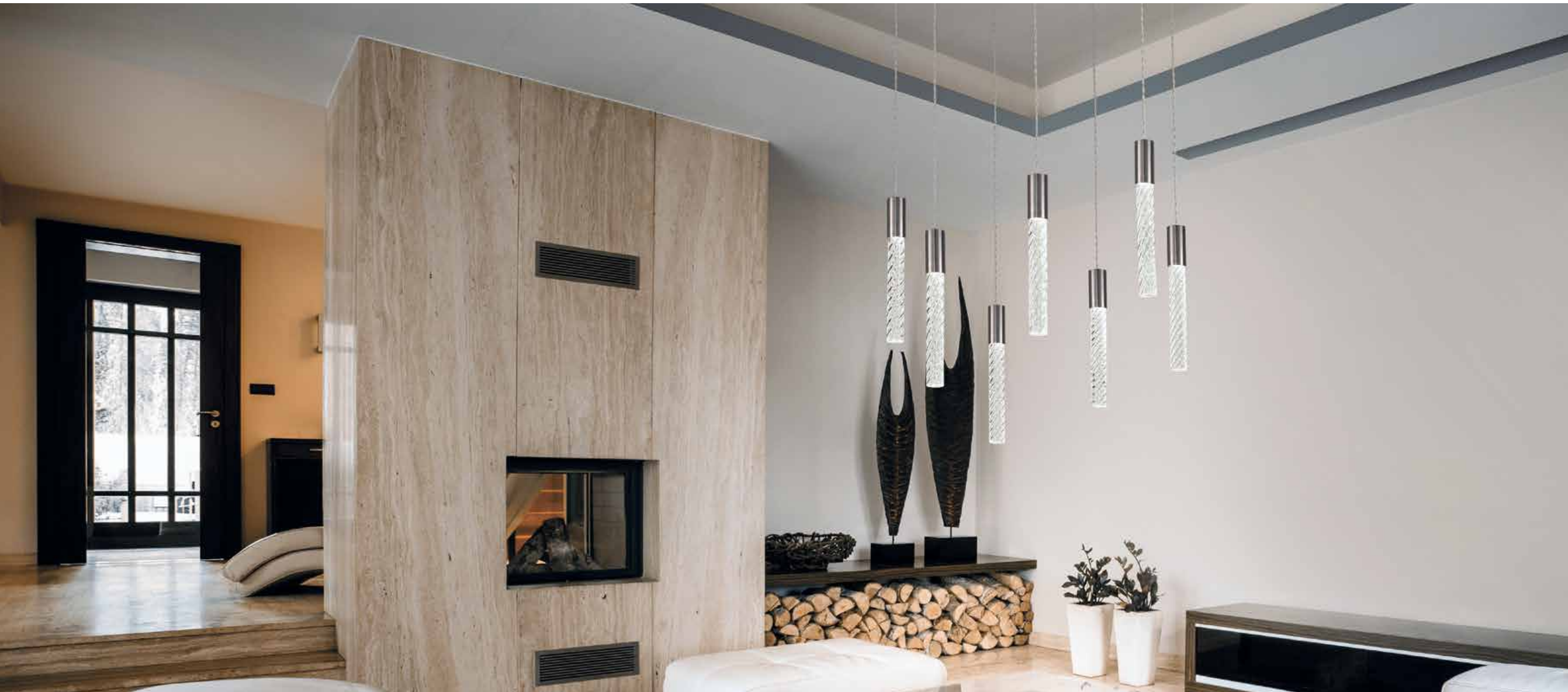

Design by Kolarz Studio



6008.30659.0 + 5340.G01.Fm

Modernes Licht mit dem richtigen Dreh: Feinstes Metall trifft mundgeblasenes, von Hand gedrehtes Muranoglas in wunderbarem Material-Mix. Das reizvolle Resultat dieser Kombination: eine lebendige, stylisch-moderne LED-Lichtquelle in minimalistischem Design. La luce è mobile ...

Modern lighting with a twist: Finest metal meets mouth-blown Murano glass twisted by hand – a marvellous mix of materials. The stunning result of this combination: a vivid, contemporary LED light in a purist and sleek design. La luce è mobile ...



6008.31259.0 + 5340.G01.T

MOBILE MURANO 2



60

6008.30159.0 + 5340.G01.T

6008.30159.0 + 5340.G01.Fm

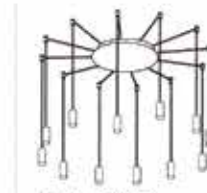

⊗ 50 - 150 cm
⊠ 100 - 200 cm
⊚ 12 lp., GU10 Mini



⊗ 50 - 150 cm
⊠ 100 - 200 cm
⊚ 6 lp., GU10 Mini



⊗ 12,5 cm
⊠ 160 cm
⊚ 1 lp., GU10 Mini



⊠ 11 / 50 cm
⊠ 18,5 cm
⊚ 1 lp., GU10 Mini

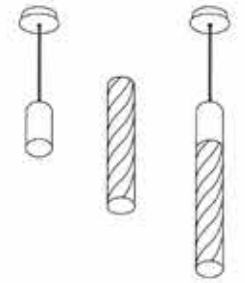

 dark chrome	6008.31259.0	6008.30659.0	6008.30159.0	6008.60159.0
---	--------------	--------------	--------------	--------------

Decor



⊗ 4 cm
⊠ 25 cm

 glass crystal	5340.G01.T
 glass fumé	5340.G01.Fm



CLOUD



Design by Kolarz Studio



5324.32050



5324.32050

Lichtdesign, inspiriert von der Natur: Unsere Cloud schwebt scheinbar schwerelos im Raum und schafft atmosphärische Akzente. Feinste Metallketten formen schimmernde Wolken und sorgen für aufregende Licht- und Schatteneffekte. Spektakulärer Blickpunkt und Wow-Faktor in jedem Setting.

Light design, inspired by nature: Our Cloud seems to float below the ceiling and creates atmospheric accents. Finest metal chains, forming shimmering clouds, create amazing effects of light and shadow. An impressive, spectacular focal point and wow factor in any setting.



5324.32050



5320.60350



5320.40150



5323.30750



5323.30550



5323.30150

CLOUD

■ Frame: chrome

		 * can be used as ceiling light		 * can be used as ceiling light		
	<ul style="list-style-type: none"> □ 140 / 65 cm □ 22 / max. 200 cm □ 20 lp., G9, 40 W 	<ul style="list-style-type: none"> □ 140 / 65 cm □ 22 / max. 200 cm □ 20 lp., G9, 40 W 	<ul style="list-style-type: none"> □ 100 / 35 cm □ 20 / max. 200 cm □ 12 lp., G9, 40 W 	<ul style="list-style-type: none"> □ 100 / 35 cm □ 20 / max. 200 cm □ 12 lp., G9, 40 W 	<ul style="list-style-type: none"> □ 130 / 14 cm □ 20 / max. 220 cm □ 7 lp., G9, 40 W 	<ul style="list-style-type: none"> □ 85 / 14 cm □ 20 / max. 220 cm □ 5 lp., G9, 40 W
	5324.32050 *	5324.32050	5324.31250 *	5324.31250	5323.30750	5323.30550
		 * can be used as ceiling light				
	<ul style="list-style-type: none"> □ 14 cm □ 25 / max. 150 cm □ 1 lp., E27, 60 W 	<ul style="list-style-type: none"> □ 14 cm □ 25 / max. 150 cm □ 1 lp., E27, 60 W 	<ul style="list-style-type: none"> □ 30 cm □ 150 cm □ 1 lp., PAR E27, 100 W 	<ul style="list-style-type: none"> □ 50 / 20 cm □ 10 cm □ 3 lp., G9, 40 W 		
	5323.30150 *	5323.30150	5320.40150	5320.60350		

SPADA



Design by Kolarz Studio



Projekt mit 5 Elementen 6000.30159
Project with 5 elements 6000.30159





6000.30159



Minimalistischer Metallic-Look mit maximaler Wirkung: Mit Spada, benannt nach dem inspirierenden Schwertfisch, schwebt ein spektakuläres neues Lichtdesign im Raum. Flexibel montierbare konische Metallrohre in edlem Dark-Chrome-Finish tragen dimmbare warmweiß strahlende LEDs.

Minimalist metallic look with maximum impact: Spada, inspired by the shape of the swordfish, appears to float from the ceiling. Flexible mounting options in various angles make this a very special design. The conical dark chrome metal bars hold LEDs giving warm-white light.

SPADA

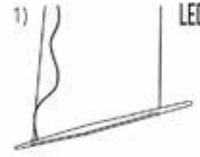

6000.40159

	 <p>1) LED</p> <ul style="list-style-type: none"> 125 cm 5 cm / max. 205 cm LED STRIP, 18 W 2200 lm, 2700 K dimmable 	 <p>LED</p> <ul style="list-style-type: none"> 40 cm / 30 cm 160 cm LED STRIP, 18 W 2200 lm, 2700 K touch dimmer
 <p>dark chrome</p>	6000.30159	6000.40159

KOLARZ® CRYSTAL DIFFUSER



Rosette



1) optional



1)

- PUSH
- DALI
- 0-10 V
- LINEAR 100KQ

DIM

1) optional

- DIM TRIAC

FONTE DI LUCE



Design by Domenico Rinaldi



5310.10154.940



5310.1053.940

Perfekte Illusion – pure Faszination: Inspiriert von der Schönheit natürlicher Wasserfälle, fließt die von Domenico Rinaldi entworfene Fonte di Luce scheinbar direkt von der Decke oder Wand. Tausende funkelnde Kristalle sorgen für Wow-Effekt in jedem Raum. Eine wahrlich spektakuläre Lichtquelle.

Perfect illusion – pure fascination: Inspired by the beauty of natural waterfalls, Domenico Rinaldi's Fonte di Luce seems to flow directly down from the ceiling or wall. Thousands of sparkling crystals add the wow factor to any room. A truly spectacular source of light.



5310.10350.940



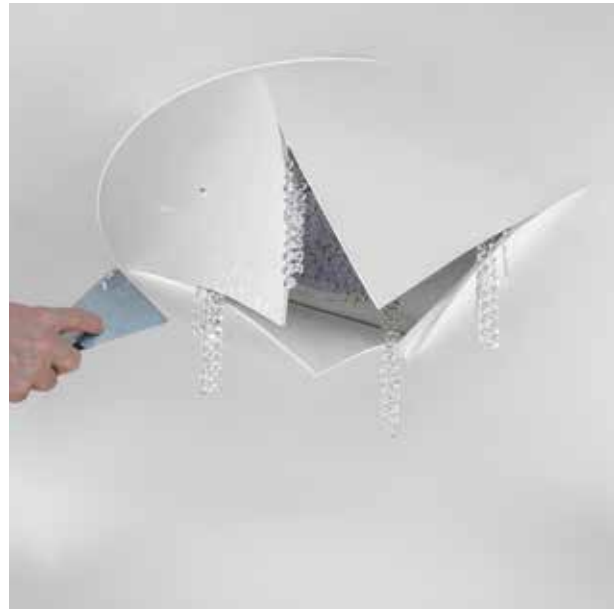
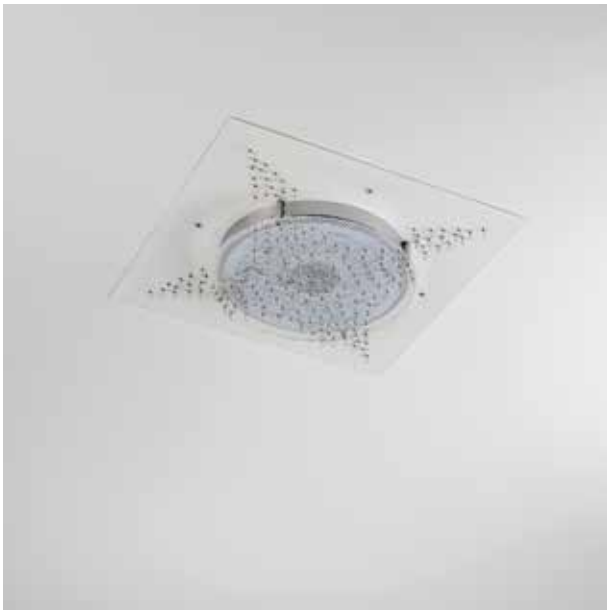



FONTE DI LUCE



Frame: white

	 LED	 LED	 LED	 LED	 LED
	120 cm 52 cm 3 lp., 13 W, dimmable, 4350 lm, 3000 K	80 cm 52 cm 1 lp., 48 W, dimmable, 4270 lm, 3000 K	55 cm 43 cm 1 lp., 14 W, dimmable, 1350 lm, 3000 K	25 cm 34 cm 1 lp., 13 W, dimmable, 1000 lm, 3000 K	30 / 70 cm 11 cm 1 lp., 13 W, dimmable, 1000 lm, 3000 K
OPTIC® KOLARZ® clear	5310.10350.940	5310.10154.940	5310.10153.940	5310.10152.940	5310.60150.940

Frame: 24 carat gold plated

	 LED	 LED	 LED	 LED	 LED
	120 cm 52 cm 3 lp., 13 W, dimmable, 4350 lm, 3000 K	80 cm 52 cm 1 lp., 48 W, dimmable, 4270 lm, 3000 K	55 cm 43 cm 1 lp., 14 W, dimmable, 1350 lm, 3000 K	25 cm 34 cm 1 lp., 13 W, dimmable, 1000 lm, 3000 K	30 / 70 cm 11 cm 1 lp., 13 W, dimmable, 1000 lm, 3000 K
OPTIC® KOLARZ® clear	5313.10350.940	5313.10154.940	5313.10153.940	5313.10152.940	5313.60150.940

Frame: silver plated

	 LED	 LED	 LED	 LED	 LED
	120 cm 52 cm 3 lp., 13 W, dimmable, 4350 lm, 3000 K	80 cm 52 cm 1 lp., 48 W, dimmable, 4270 lm, 3000 K	55 cm 43 cm 1 lp., 14 W, dimmable, 1350 lm, 3000 K	25 cm 34 cm 1 lp., 13 W, dimmable, 1000 lm, 3000 K	30 / 70 cm 11 cm 1 lp., 13 W, dimmable, 1000 lm, 3000 K
OPTIC® KOLARZ® clear	5315.10350.940	5315.10154.940	5315.10153.940	5315.10152.940	5315.60150.940

VIRGOLA

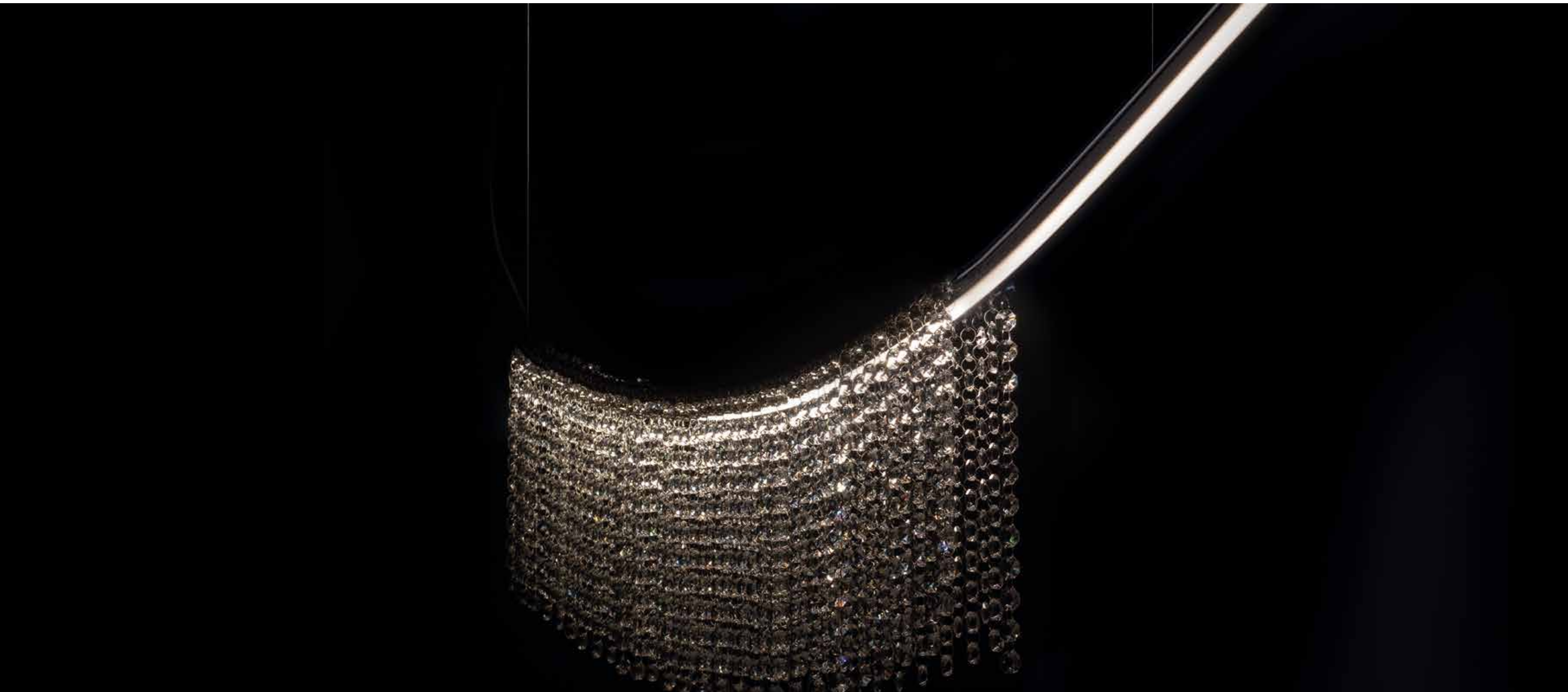

Design by Kolarz Studio



Projekt mit 2 Elementen 6002.30159.140 / 6002.30259.140
Project with 2 elements 6002.30159.140 / 6002.30259.140

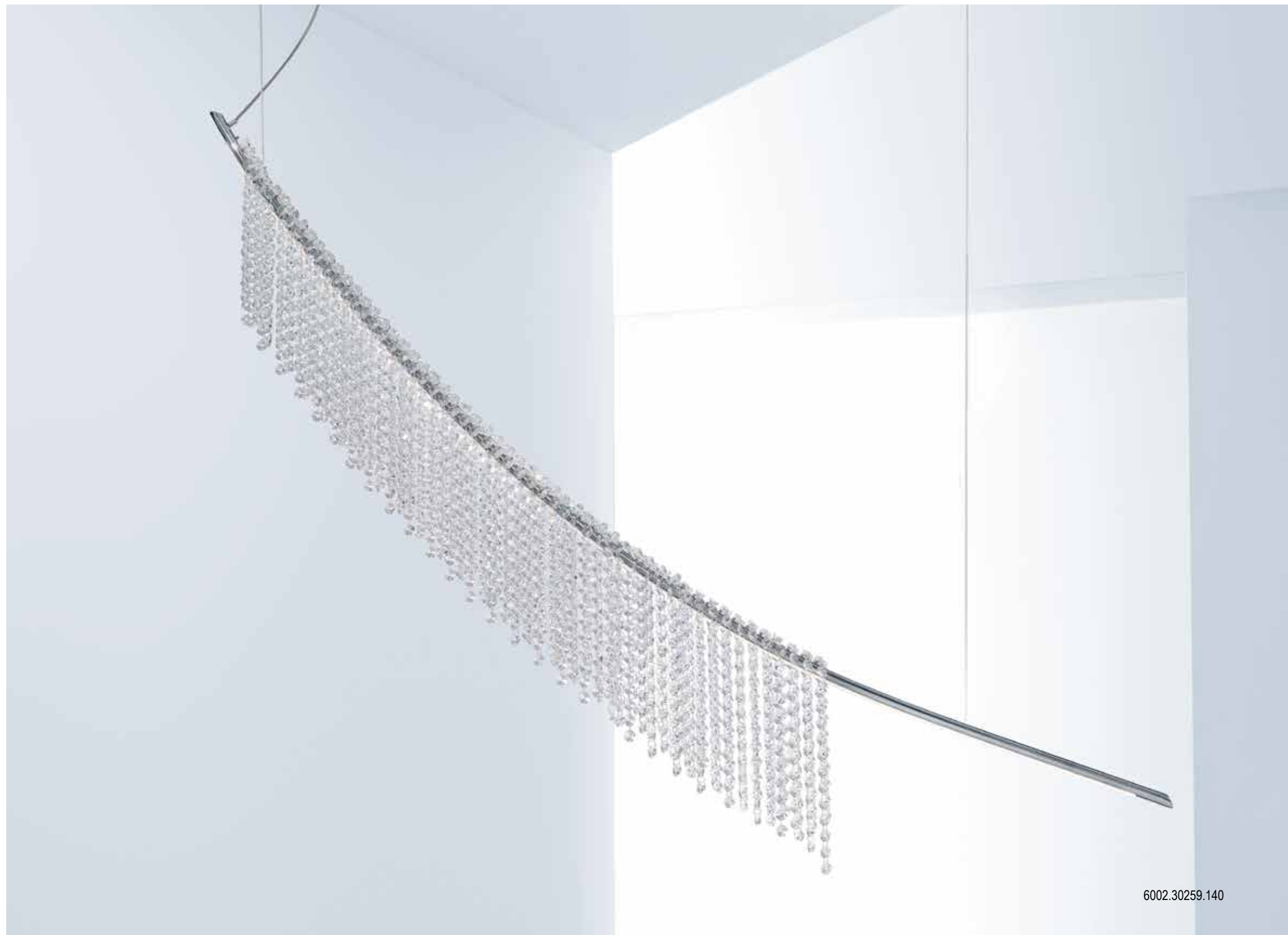

6002.30259.140

Virgola, der „Beistrich“, steht für pures Understatement und spannenden Minimalismus mit maximalem Effekt. Ein kommaförmiger Metallbogen in edlem Dark-Chrome-Finish hält Hunderte funkelnde Kristalle in KOLARZ-Optic-Qualität, die von dimmbaren warmweißen LEDs beleuchtet werden.

Virgola, the Italian word for “comma”, represents pure understatement and exciting minimalism with maximum impact. A clean dark chrome finished metal bow, curved like a comma, holds hundreds of sparkling KOLARZ Optic crystals, lit by dimmable LEDs giving warm-white light.



6002.60159.140







6002.70159.140

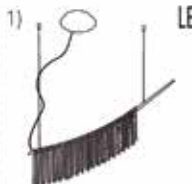

6002.40159.140

VIRGOLA

Crystal: OPTIC® KOLARZ® Crystal Clear

	1)	1)			
					
	160 cm 25 cm / max. 225 cm LED STRIP, 30 W 3700 lm, 2700 K dimmable	120 cm 25 cm / max. 225 cm LED STRIP, 21 W 2600 lm, 2700 K dimmable	13 / 50 cm 50 cm LED STRIP, 6 W 700 lm, 2700 K	23 / 17 cm 20 cm LED STRIP, 6 W 700 lm, 2700 K	40 / 30 cm 180 cm LED STRIP, 21 W 2500 lm, 2700 K touch dimmer
 dark chrome	6002.30259.140	6002.30159.140	6002.60159.140	6002.70159.140	6002.40159.140

KOLARZ® CRYSTAL DIFFUSER

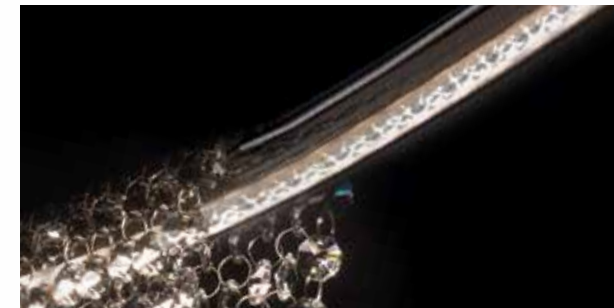

Rosette

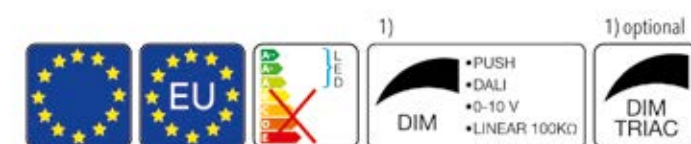

PRISMA SLIM

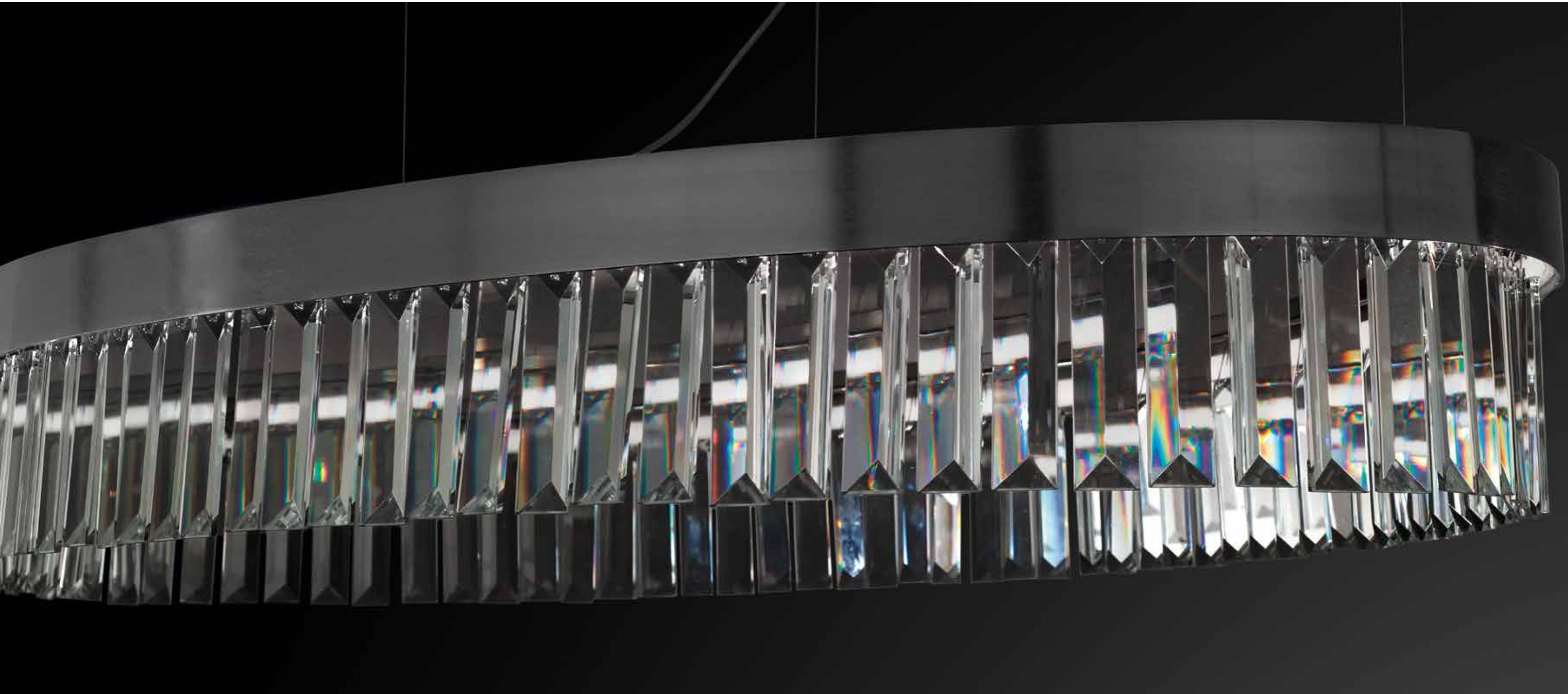

Design by Kolarz Studio



6003.30259.240



Klassik trifft Moderne, mit einem Hauch von Art Déco. Feinste KOLARZ-Optic-Kristalle mit handgefertigtem Prismenschliff, beleuchtet von dimmbaren warmweißen LEDs. Runde, ovale oder balkenförmige Metallrahmen in edlem Dark-Chrome-Finish. Zeitlose Eleganz für klassische und moderne Interiors.

Classics meet contemporary style, with a touch of Art Déco. Finest KOLARZ Optic crystals with a handcrafted prism cut, effectfully lit by dimmable warm-white LEDs. Ring-, oval- or bar-shaped metal frames in a sleek dark chrome design. Timeless elegance for classic and modern interiors.





6003.30559.240



6003.30459.240

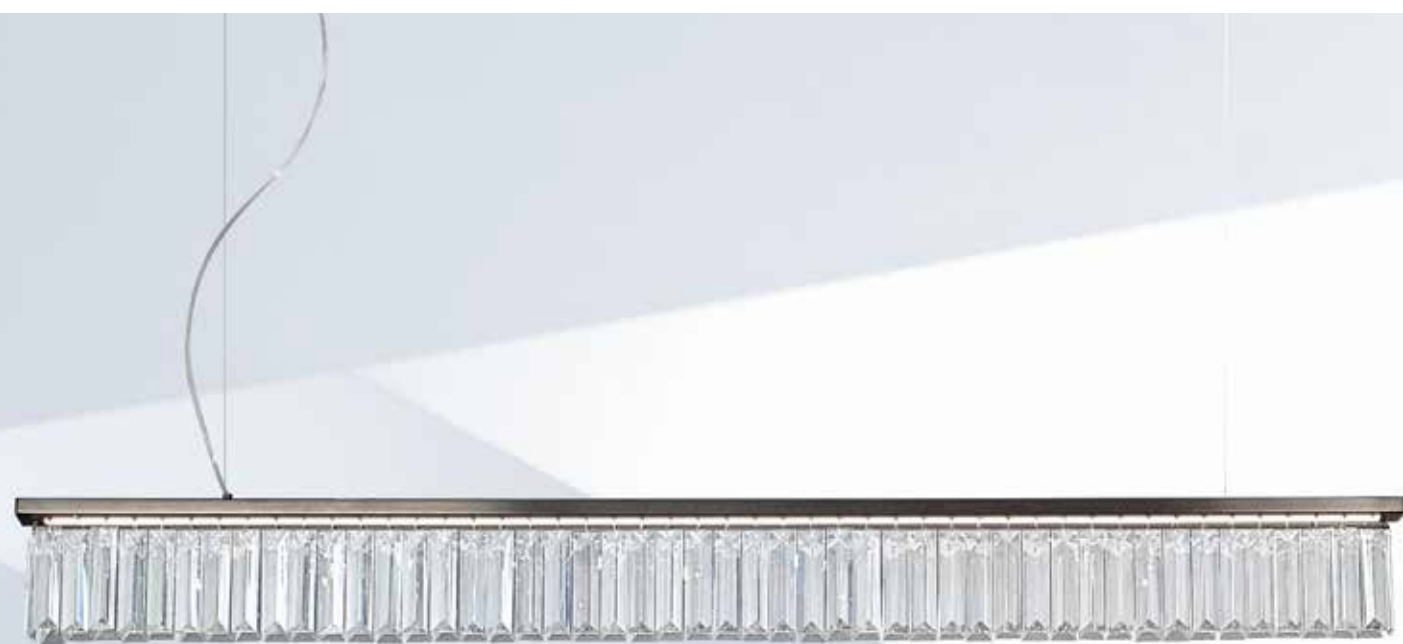



6003.30359.240



6003.60159.240

PRISMA SLIM

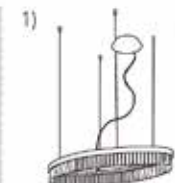
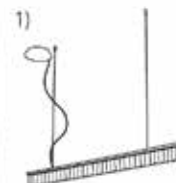
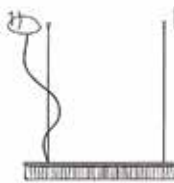
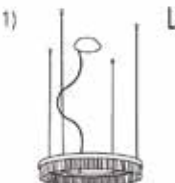
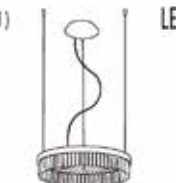
Crystal: PURE® KOLARZ® Crystal Clear

	 <p>1) LED</p> <ul style="list-style-type: none"> 106 / 60 cm 11,5 cm / max. 210 cm LED STRIP, 51 W 6200 lm, 2700 K 	 <p>1) LED</p> <ul style="list-style-type: none"> 160 cm 11,5 cm / max. 210 cm LED STRIP, 30 W 3600 lm, 2700 K 	 <p>2) LED</p> <ul style="list-style-type: none"> 120 cm 11,5 cm / max. 210 cm LED STRIP, 21 W 2600 lm, 2700 K 	 <p>1) LED</p> <ul style="list-style-type: none"> 90 cm 13 cm / max. 213 cm LED STRIP, 54 W 6700 lm, 2700 K 	 <p>1) LED</p> <ul style="list-style-type: none"> 60 cm 11,5 cm / max. 210 cm LED STRIP, 38 W 4500 lm, 2700 K 	 <p>LED</p> <ul style="list-style-type: none"> 34 / 13 cm 13 cm LED STRIP, 6 W 720 lm, 2700 K
 <p>dark chrome</p>	6003.30559.240	6003.30459.240	6003.30359.240	6003.30259.240	6003.30159.240	6003.60159.240

KOLARZ® CRYSTAL DIFFUSER



Rosette

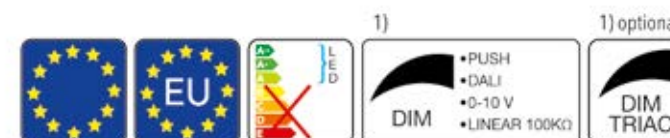

PRISMA

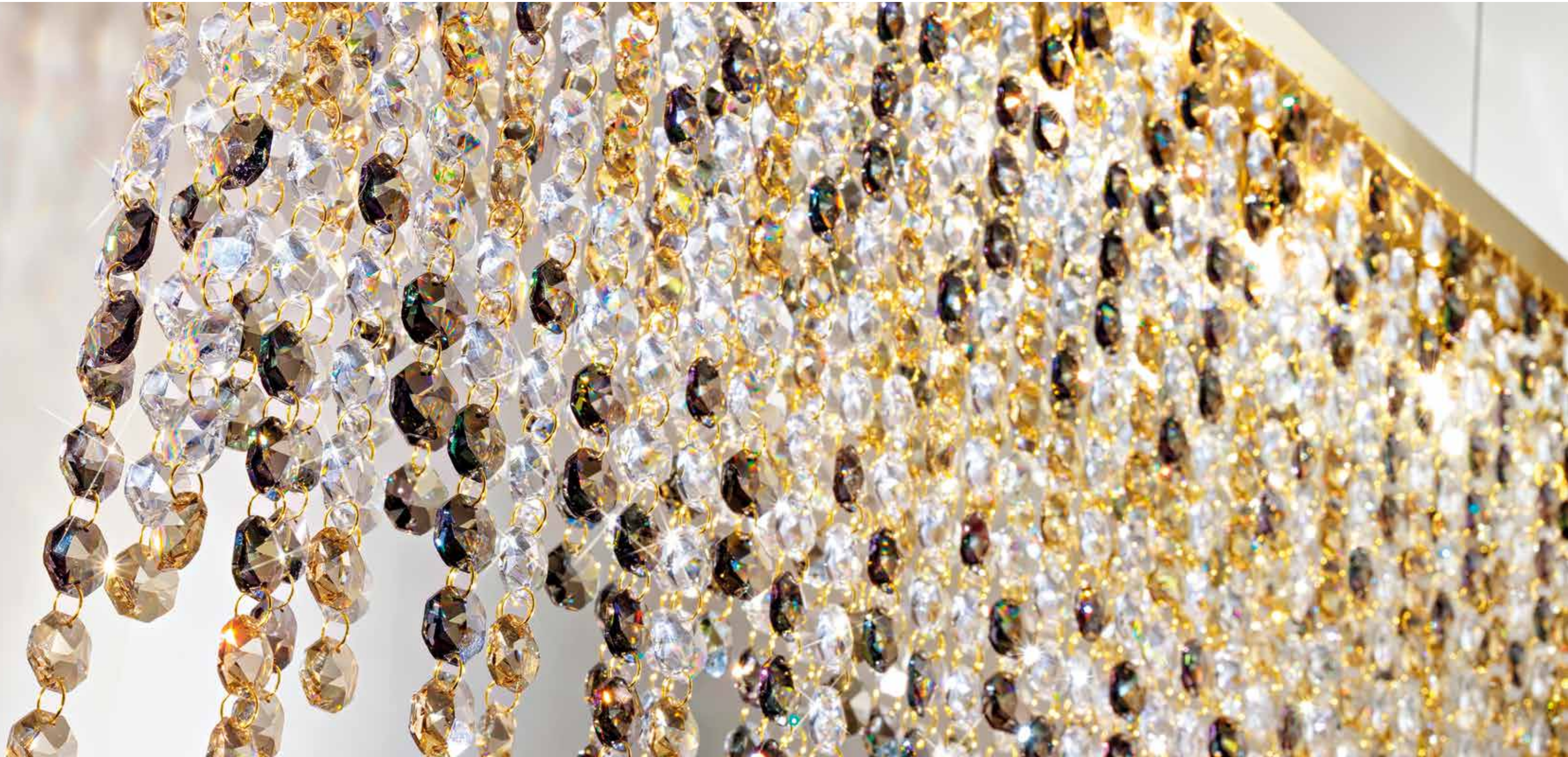

Design by Kolarz Studio



1314.87.3.P1.KpTGn



1314.87.3.01.KpT

Wenn Märchen wahr werden: Prisma verleiht jedem Raum Grandezza und Glamour. Feinste Metalle und Stoffe, farbenprächtige Kristalle. Eine echte Augenweide.

When fairy tales come true: Prisma adds grandezza and glamour to any room. Finest metals and fabrics, sparkling colourful crystals. A veritable feast for the eyes.

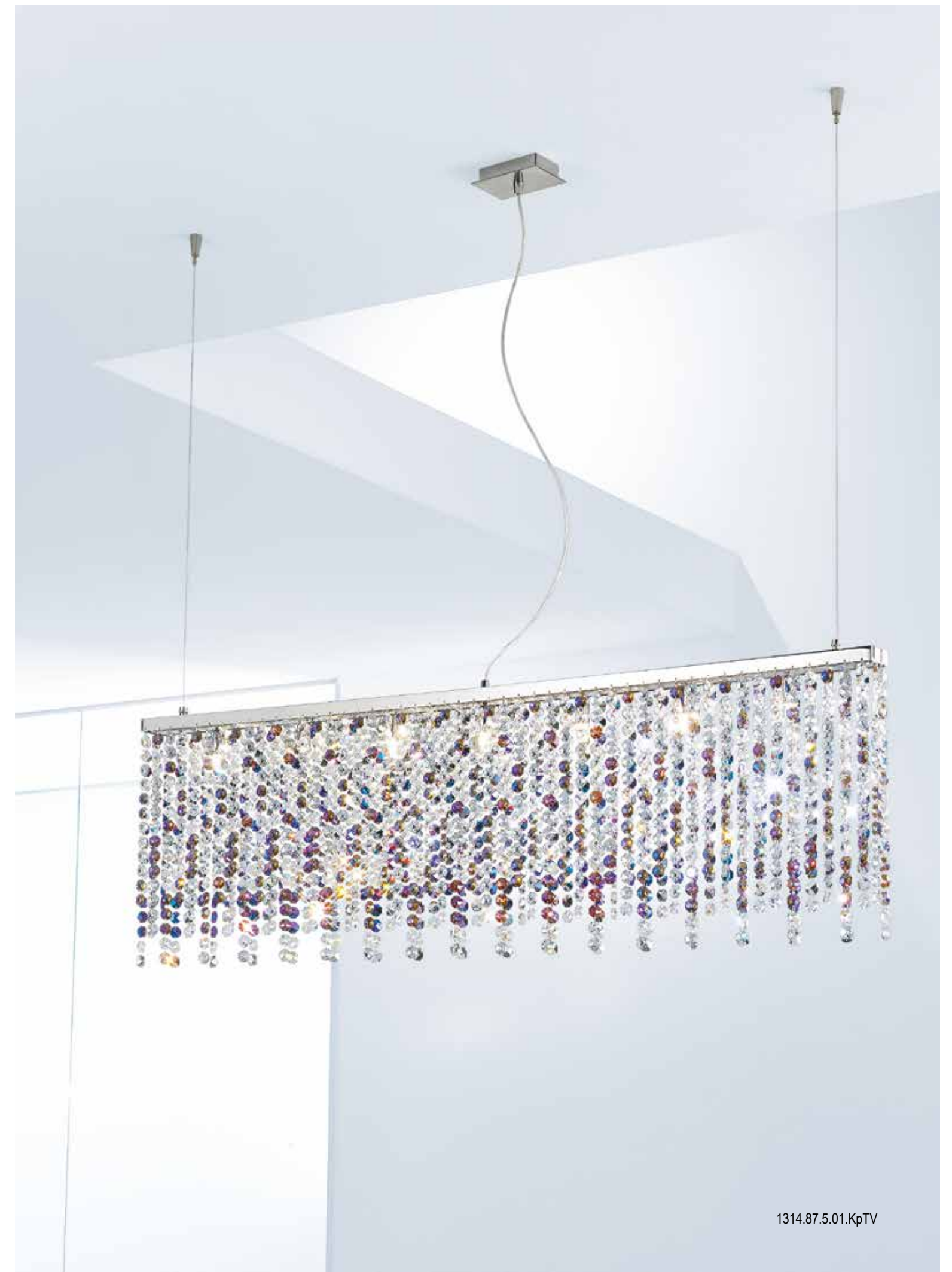

1314.87.5.01.KpTV



1314.87.5.P1.KpT + 314.502.W



1314.810.5.P1.KpT + 314.504.Bk



1314.87.5.P1.KpTV



1314.31M.5.P1.KpT

1314.31M.3.P1.KpT



314.11M.5



314.11M.3



1344.31M.3.P1.KpT

1344.31M.5.01.KpTV



344.11M.3



344.11M.5



1344.112.5.P1.KpT



1344.112.3.P1.KpTGn



1344.16.5.P1.KpTV



344.112.3



344.16.5



1314.116.5.01.KpTV

1314.18.3.P1.KpTGn



314.116.3

314.18.5



1314.11MQ.5.KpTV



1314.11MQ.3.KpTGn



1314.63.3.01.KpTGn



1344.11MQ.5.KpTV



1344.11M.3.KpTGn



1314.65.5.P1.KpTV

PRISMA



Frame: 24 carat gold plated

	160 cm 28 cm / 33 - 250 cm 10 lp., G9, 25 W	120 cm 20 cm / 27 - 250 cm 7 lp., G9, 25 W
	Spectra® 314.810.3	314.87.3
	MQ KpT 1314.810MQ.3.KpT	1314.87MQ.3.KpT
	MQ KpTGn 1314.810MQ.3.KpTGn	1314.87MQ.3.KpTGn
	O1 KpT 1314.810.3.O1.KpT	1314.87.3.O1.KpT
	O1 KpTGn 1314.810.3.O1.KpTGn	1314.87.3.O1.KpTGn
	P1 KpT 1314.810.3.P1.KpT	1314.87.3.P1.KpT
	P1 KpTGn 1314.810.3.P1.KpTGn	1314.87.3.P1.KpTGn

	180 cm shade optional for hanging lamp, 10 lp.	130 cm shade optional for hanging lamp, 7 lp.
	shade white 314.S04.W	314.S02.W
	shade black 314.S04.Bk	314.S02.Bk

Frame: chrome plated

	Spectra® 314.810.5	314.87.5
	MQ KpT 1314.810MQ.5.KpT	1314.87MQ.5.KpT
	MQ KpTV 1314.810MQ.5.KpTV	1314.87MQ.5.KpTV
	O1 KpT 1314.810.5.O1.KpT	1314.87.5.O1.KpT
	O1 KpTV 1314.810.5.O1.KpTV	1314.87.5.O1.KpTV
	P1 KpT 1314.810.5.P1.KpT	1314.87.5.P1.KpT
	P1 KpTV 1314.810.5.P1.KpTV	1314.87.5.P1.KpTV



PRISMA

Frame: 24 carat gold plated

						
	Ø 60 cm □ 20 cm ☑ 12 lp., G9, 25 W	Ø 45 cm □ 20 cm ☑ 6 lp., G9, 25 W	□ 55 / 55 cm □ 20 cm ☑ 16 lp., G9, 25 W	□ 40 / 40 cm □ 20 cm ☑ 8 lp., G9, 25 W	□ 12 / 12 cm □ 85 cm ☑ 1 lp., G9, 25 W	□ 12 cm □ 85 cm ☑ 1 lp., G9, 25 W
 Spectra®	344.112.3	344.16.3	314.116.3	314.18.3	314.31M.3	344.31M.3
 MQ KpT	1344.112MQ.3.KpT	1344.16MQ.3.KpT	1314.116MQ.3.KpT	1314.18MQ.3.KpT	1314.31MQ.3.KpT	1344.31MQ.3.KpT
 MQ KpTGn	1344.112MQ.3.KpTGn	1344.16MQ.3.KpTGn	1314.116MQ.3.KpTGn	1314.18MQ.3.KpTGn	1314.31MQ.3.KpTGn	1344.31MQ.3.KpTGn
 O1 KpT	1344.112.3.O1.KpT	1344.16.3.O1.KpT	1314.116.3.O1.KpT	1314.18.3.O1.KpT	1314.31M.3.O1.KpT	1344.31M.3.O1.KpT
 O1 KpTGn	1344.112.3.O1.KpTGn	1344.16.3.O1.KpTGn	1314.116.3.O1.KpTGn	1314.18.3.O1.KpTGn	1314.31M.3.O1.KpTGn	1344.31M.3.O1.KpTGn
 P1 KpT	1344.112.3.P1.KpT	1344.16.3.P1.KpT	1314.116.3.P1.KpT	1314.18.3.P1.KpT	1314.31M.3.P1.KpT	1344.31M.3.P1.KpT
 P1 KpTGn	1344.112.3.P1.KpTGn	1344.16.3.P1.KpTGn	1314.116.3.P1.KpTGn	1314.18.3.P1.KpTGn	1314.31M.3.P1.KpTGn	1344.31M.3.P1.KpTGn







Frame: 24 carat gold plated

			
	□ 12 / 12 cm □ 20 cm ☑ 1 lp., G9, 25 W	□ 12 cm □ 20 cm ☑ 1 lp., G9, 25 W	□ 50 / 22 cm □ 10 cm ☑ 3 lp., G9, 25 W
 Spectra®	314.11M.3	344.11M.3	314.63.3
 MQ KpT	1314.11MQ.3.KpT	1344.11MQ.3.KpT	1314.63MQ.3.KpT
 MQ KpTGn	1314.11MQ.3.KpTGn	1344.11MQ.3.KpTGn	1314.63MQ.3.KpTGn
 O1 KpT	1314.11M.3.O1.KpT	1344.11M.3.O1.KpT	1314.63.3.O1.KpT
 O1 KpTGn	1314.11M.3.O1.KpTGn	1344.11M.3.O1.KpTGn	1314.63.3.O1.KpTGn
 P1 KpT	1314.11M.3.P1.KpT	1344.11M.3.P1.KpT	1314.63.3.P1.KpT
 P1 KpTGn	1314.11M.3.P1.KpTGn	1344.11M.3.P1.KpTGn	1314.63.3.P1.KpTGn

Frame: chrome plated

 Spectra®	344.112.5	344.16.5	314.116.5	314.18.5	314.31M.5	344.31M.5
 MQ KpT	1344.112MQ.5.KpT	1344.16MQ.5.KpT	1314.116MQ.5.KpT	1314.18MQ.5.KpT	1314.31MQ.5.KpT	1344.31MQ.5.KpT
 MQ KpTV	1344.112MQ.5.KpTV	1344.16MQ.5.KpTV	1314.116MQ.5.KpTV	1314.18MQ.5.KpTV	1314.31MQ.5.KpTV	1344.31MQ.5.KpTV
 O1 KpT	1344.112.5.O1.KpT	1344.16.5.O1.KpT	1314.116.5.O1.KpT	1314.18.5.O1.KpT	1314.31M.5.O1.KpT	1344.31M.5.O1.KpT
 O1 KpTV	1344.112.5.O1.KpTV	1344.16.5.O1.KpTV	1314.116.5.O1.KpTV	1314.18.5.O1.KpTV	1314.31M.5.O1.KpTV	1344.31M.5.O1.KpTV
 P1 KpT	1344.112.5.P1.KpT	1344.16.5.P1.KpT	1314.116.5.P1.KpT	1314.18.5.P1.KpT	1314.31M.5.P1.KpT	1344.31M.5.P1.KpT
 P1 KpTV	1344.112.5.P1.KpTV	1344.16.5.P1.KpTV	1314.116.5.P1.KpTV	1314.18.5.P1.KpTV	1314.31M.5.P1.KpTV	1344.31M.5.P1.KpTV

Frame: chrome plated

 Spectra®	314.11M.5	344.11M.5	314.63.5
 MQ KpT	1314.11MQ.5.KpT	1344.11MQ.5.KpT	1314.63MQ.5.KpT
 MQ KpTV	1314.11MQ.5.KpTV	1344.11MQ.5.KpTV	1314.63MQ.5.KpTV
 O1 KpT	1314.11M.5.O1.KpT	1344.11M.5.O1.KpT	1314.63.5.O1.KpT
 O1 KpTV	1314.11M.5.O1.KpTV	1344.11M.5.O1.KpTV	1314.63.5.O1.KpTV
 P1 KpT	1314.11M.5.P1.KpT	1344.11M.5.P1.KpT	1314.63.5.P1.KpT
 P1 KpTV	1314.11M.5.P1.KpTV	1344.11M.5.P1.KpTV	1314.63.5.P1.KpTV

STRETTA



Design by Kolarz Studio

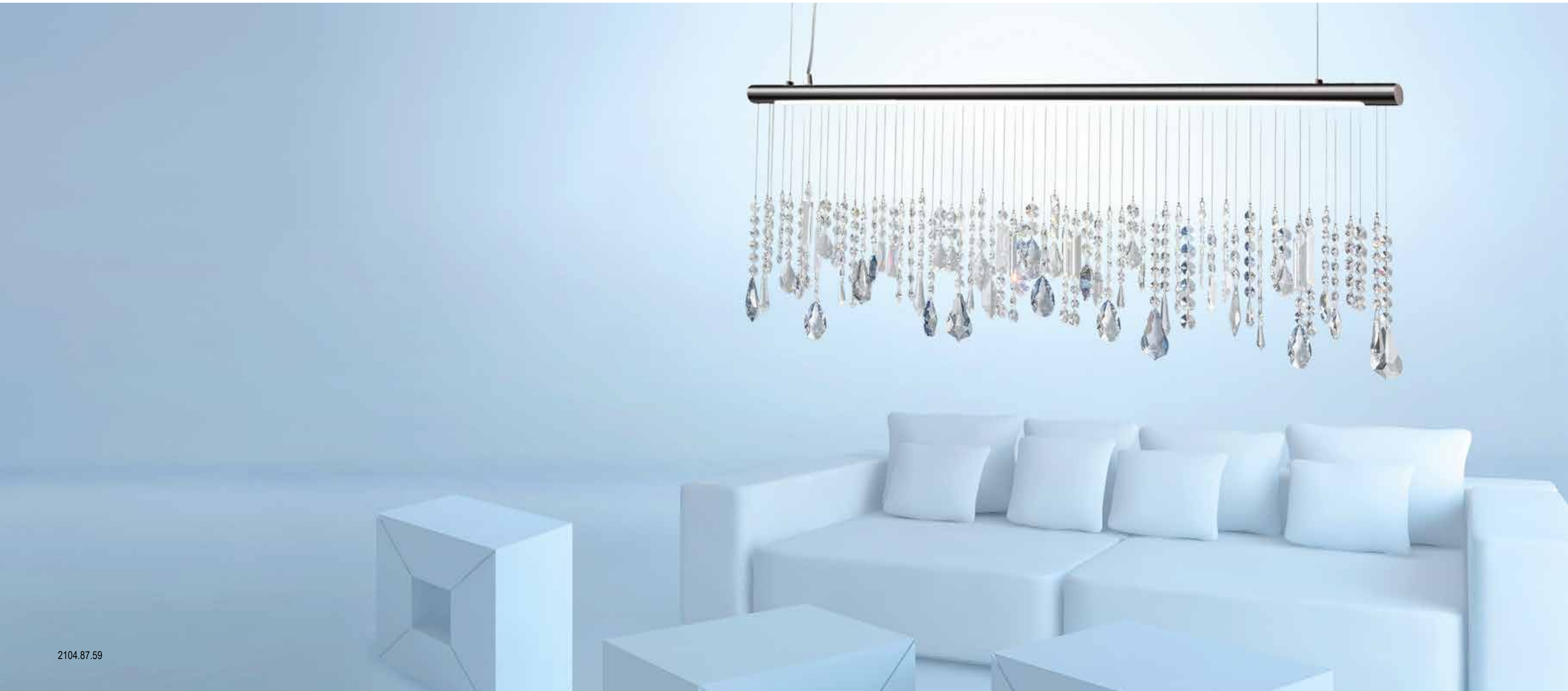

2104.87.59



2104.63.3

Ob 24 Karat Gold, Chrom oder Dark Chrome: Stretta besticht mit minimalistischem Metall-Design und der funkelnden Brillanz Hunderter Kristalle in verschiedenen Farben. Ein perfektes Licht über Esstisch und Bartheke und ein effektvoller Eyecatcher über dem Konferenztisch im Büro.

Stretta shows a sleek metal frame in 24 carat gold, chrome or dark chrome finish and hundreds of sparkling clear and coloured crystal droplets. These lights make a stylish decorative feature over dining tables, bars or as an eye-catching addition to the board room over a conference table.



027.810.5











STRETTA







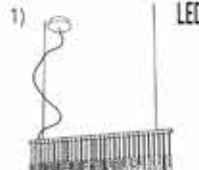

■ Frame: 24 carat gold plated

	1) LED	1) LED	LED
			
	120 cm 44 cm / 53 - 250 cm LED, 24 W, dimmable, 2880 lm, 2700 K	83 cm 44 cm / 53 - 250 cm LED, 16 W, dimmable, 1920 lm, 2700 K	49 / 40 cm 9 cm LED, 10 W, dimmable, 1170 lm, 2700 K
 SPECTRA® clear	2104.87.3	2104.85.3	2104.63.3
 SPECTRA® clear SWAROVSKI® pink/amber/purple	2104.87.3.STR NEU	2104.85.3.STR NEU	2104.63.3.STR NEU
 SPECTRA® clear SWAROVSKI® black	2104.87.3.STR JET	2104.85.3.STR JET	2104.63.3.STR JET
 SPECTRA® clear SWAROVSKI® blue/bronze shade	2104.87.3.ETBS	2104.85.3.ETBS	2104.63.3.ETBS
 OPTIC® KOLARZ® clear	2104.87.3.KoT	2104.85.3.KoT	2104.63.3.KoT

■ Frame: dark chrome plated

	1) LED	1) LED	LED
			
	120 cm 44 cm / 53 - 250 cm LED, 24 W, dimmable, 2880 lm, 2700 K	83 cm 44 cm / 53 - 250 cm LED, 16 W, dimmable, 1920 lm, 2700 K	49 / 40 cm 9 cm LED, 10 W, dimmable, 1170 lm, 2700 K
 SPECTRA® clear	2104.87.59	2104.85.59	2104.63.59
 SPECTRA® clear SWAROVSKI® pink/amber/purple	2104.87.59.STR NEU	2104.85.59.STR NEU	2104.63.59.STR NEU
 SPECTRA® clear SWAROVSKI® black	2104.87.59.STR JET	2104.85.59.STR JET	2104.63.59.STR JET
 SPECTRA® clear SWAROVSKI® blue/bronze shade	2104.87.59.ETBS	2104.85.59.ETBS	2104.63.59.ETBS
 OPTIC® KOLARZ® clear	2104.87.59.KoT	2104.85.59.KoT	2104.63.59.KoT

■ Frame: chrome plated

	1) LED	1) LED	LED
			
	120 cm 44 cm / 53 - 250 cm LED, 24 W, dimmable, 2880 lm, 2700 K	83 cm 44 cm / 53 - 250 cm LED, 16 W, dimmable, 1920 lm, 2700 K	49 / 40 cm 9 cm LED, 10 W, dimmable, 1170 lm, 2700 K
 SPECTRA® clear	2104.87.5	2104.85.5	2104.63.5
 SPECTRA® clear SWAROVSKI® pink/amber/purple	2104.87.5.STR NEU	2104.85.5.STR NEU	2104.63.5.STR NEU
 SPECTRA® clear SWAROVSKI® black	2104.87.5.STR JET	2104.85.5.STR JET	2104.63.5.STR JET
 SPECTRA® clear SWAROVSKI® blue/bronze shade	2104.87.5.ETBS	2104.85.5.ETBS	2104.63.5.ETBS
 OPTIC® KOLARZ® clear	2104.87.5.KoT	2104.85.5.KoT	2104.63.5.KoT

KOLARZ® CRYSTAL DIFFUSER



Rosette





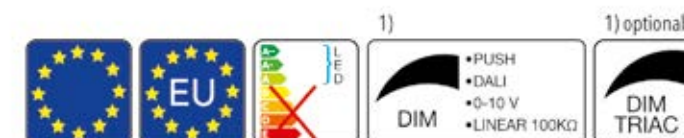





Rosette











STRETTA

Frame: 24 carat gold plated

				
	80 cm 58 cm / 75 - 250 cm 10 lp., G9, 40 W	120 cm 44 cm / 53 - 250 cm 7 lp., G9, 40 W	83 cm 44 cm / 53 - 250 cm 5 lp., G9, 40 W	49 / 40 cm 9 cm 3 lp., G9, 40 W
 SPECTRA® clear	027.810.3	104.87.3	104.85.3	104.63.3
 SPECTRA® clear SWAROVSKI® pink/amber/purple	027.810.3.STR NEU	104.87.3.STR NEU	104.85.3.STR NEU	104.63.3.STR NEU
 SPECTRA® clear SWAROVSKI® black	027.810.3.STR JET	104.87.3.STR JET	104.85.3.STR JET	104.63.3.STR JET
 SPECTRA® clear SWAROVSKI® blue/bronze shade	027.810.3.ETBS	104.87.3.ETBS	104.85.3.ETBS	104.63.3.ETBS
 OPTIC® KOLARZ® clear	027.810.3.KoT	104.87.3.KoT	104.85.3.KoT	104.63.3.KoT

Frame: chrome plated

				
	80 cm 50 cm / 75 - 250 cm 10 lp., G9, 40 W	120 cm 44 cm / 53 - 250 cm 7 lp., G9, 40 W	83 cm 44 cm / 53 - 250 cm 5 lp., G9, 40 W	49 / 40 cm 9 cm 3 lp., G9, 40 W
 SPECTRA® clear	027.810.5	104.87.5	104.85.5	104.63.5
 SPECTRA® clear SWAROVSKI® pink/amber/purple	027.810.5.STR NEU	104.87.5.STR NEU	104.85.5.STR NEU	104.63.5.STR NEU
 SPECTRA® clear SWAROVSKI® black	027.810.5.STR JET	104.87.5.STR JET	104.85.5.STR JET	104.63.5.STR JET
 SPECTRA® clear SWAROVSKI® blue/bronze shade	027.810.5.ETBS	104.87.5.ETBS	104.85.5.ETBS	104.63.5.ETBS
 OPTIC® KOLARZ® clear	027.810.5.KoT	104.87.5.KoT	104.85.5.KoT	104.63.5.KoT

Rosette

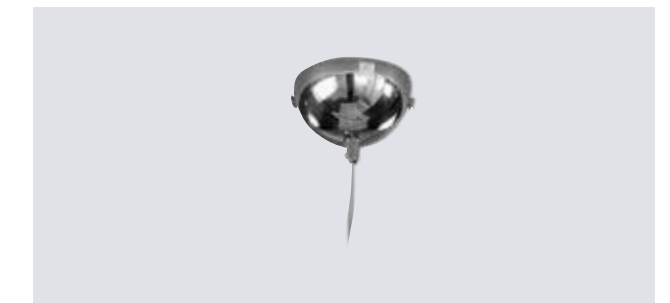
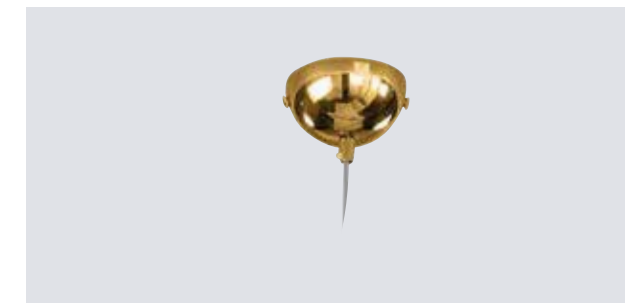

PARALUME



Design by Kolarz Studio



0240.89L.5.V.STR NEU



0240.86.3.W.KoT

Wie Diamanten am Himmel: funkelnde Kristalle, klar oder in verschiedenen Farben, 24 Karat Gold oder Chrom, feinsten semitransparenter Organza und fantastisches Design. Spektakuläre Lichtobjekte, handgefertigt im Herzen Europas. Leben und funkeln lassen: Paralume ist pure Magie.

Like diamonds in the sky: sparkling crystals, clear or in various colours, 24 carat gold or chrome, finest semi-transparent organza and fabulous design. Spectacular lighting objects, handmade in the heart of Europe. Live and let sparkle: Paralume is pure magic.



0240.87.5.W.BS

PARALUME

Frame: 24 carat gold plated Crystal: OPTIC® KOLARZ® Crystal Clear

	 80 cm 50 cm / 75 - 250 cm 9 lp., G9, 40 W	 60 cm 50 cm / 70 - 250 cm 6 lp., G9, 40 W	 180 / 30 cm 50 cm / 57 - 300 cm 9 lp., G9, 40 W	 140 / 27 cm 50 cm / 57 - 250 cm 7 lp., G9, 40 W	 90 / 27 cm 50 cm / 57 - 250 cm 5 lp., G9, 40 W	 36 / 46 cm 15 cm 2 lp., G9, 40 W
shade white	0240.89.3.W.KoT	0240.86.3.W.KoT	0240.89L.3.W.KoT	0240.87.3.W.KoT	0240.85.3.W.KoT	0240.62.3.W.KoT
shade purple	0240.89.3.V.KoT	0240.86.3.V.KoT	0240.89L.3.V.KoT	0240.87.3.V.KoT	0240.85.3.V.KoT	0240.62.3.V.KoT
shade black	0240.89.3.Bk.KoT	0240.86.3.Bk.KoT	0240.89L.3.Bk.KoT	0240.87.3.Bk.KoT	0240.85.3.Bk.KoT	0240.62.3.Bk.KoT

Frame: 24 carat gold plated Crystal: SPECTRA® Clear

	 80 cm 50 cm / 75 - 250 cm 9 lp., G9, 40 W	 60 cm 50 cm / 70 - 250 cm 6 lp., G9, 40 W	 180 / 30 cm 50 cm / 57 - 300 cm 9 lp., G9, 40 W	 140 / 27 cm 50 cm / 57 - 250 cm 7 lp., G9, 40 W	 90 / 27 cm 50 cm / 57 - 250 cm 5 lp., G9, 40 W	 36 / 46 cm 15 cm 2 lp., G9, 40 W
shade white	0240.89.3.W	0240.86.3.W	0240.89L.3.W	0240.87.3.W	0240.85.3.W	0240.62.3.W
shade purple	0240.89.3.V	0240.86.3.V	0240.89L.3.V	0240.87.3.V	0240.85.3.V	0240.62.3.V
shade black	0240.89.3.Bk	0240.86.3.Bk	0240.89L.3.Bk	0240.87.3.Bk	0240.85.3.Bk	0240.62.3.Bk

Frame: 24 carat gold plated Crystal: SWAROVSKI® Pink/Amber/Purple + SPECTRA® Clear

	 80 cm 50 cm / 75 - 250 cm 9 lp., G9, 40 W	 60 cm 50 cm / 70 - 250 cm 6 lp., G9, 40 W	 180 / 30 cm 50 cm / 57 - 300 cm 9 lp., G9, 40 W	 140 / 27 cm 50 cm / 57 - 250 cm 7 lp., G9, 40 W	 90 / 27 cm 50 cm / 57 - 250 cm 5 lp., G9, 40 W	 36 / 46 cm 15 cm 2 lp., G9, 40 W
	0240.89.3.W.STR NEU	0240.86.3.W.STR NEU	0240.89L.3.W.STR NEU	0240.87.3.W.STR NEU	0240.85.3.W.STR NEU	0240.62.3.W.STR NEU
	0240.89.3.V.STR NEU	0240.86.3.V.STR NEU	0240.89L.3.V.STR NEU	0240.87.3.V.STR NEU	0240.85.3.V.STR NEU	0240.62.3.V.STR NEU
	0240.89.3.Bk.STR NEU	0240.86.3.Bk.STR NEU	0240.89L.3.Bk.STR NEU	0240.87.3.Bk.STR NEU	0240.85.3.Bk.STR NEU	0240.62.3.Bk.STR NEU

Frame: 24 carat gold plated Crystal: SWAROVSKI® Black + SPECTRA® Clear

	 80 cm 50 cm / 75 - 250 cm 9 lp., G9, 40 W	 60 cm 50 cm / 70 - 250 cm 6 lp., G9, 40 W	 180 / 30 cm 50 cm / 57 - 300 cm 9 lp., G9, 40 W	 140 / 27 cm 50 cm / 57 - 250 cm 7 lp., G9, 40 W	 90 / 27 cm 50 cm / 57 - 250 cm 5 lp., G9, 40 W	 36 / 46 cm 15 cm 2 lp., G9, 40 W
shade white	0240.89.3.W.STR JET	0240.86.3.W.STR JET	0240.89L.3.W.STR JET	0240.87.3.W.STR JET	0240.85.3.W.STR JET	0240.62.3.W.STR JET
shade purple	0240.89.3.V.STR JET	0240.86.3.V.STR JET	0240.89L.3.V.STR JET	0240.87.3.V.STR JET	0240.85.3.V.STR JET	0240.62.3.V.STR JET
shade black	0240.89.3.Bk.STR JET	0240.86.3.Bk.STR JET	0240.89L.3.Bk.STR JET	0240.87.3.Bk.STR JET	0240.85.3.Bk.STR JET	0240.62.3.Bk.STR JET

Frame: 24 carat gold plated Crystal: SWAROVSKI® Blue/Bronze shade + SPECTRA® Clear

	 80 cm 50 cm / 75 - 250 cm 9 lp., G9, 40 W	 60 cm 50 cm / 70 - 250 cm 6 lp., G9, 40 W	 180 / 30 cm 50 cm / 57 - 300 cm 9 lp., G9, 40 W	 140 / 27 cm 50 cm / 57 - 250 cm 7 lp., G9, 40 W	 90 / 27 cm 50 cm / 57 - 250 cm 5 lp., G9, 40 W	 36 / 46 cm 15 cm 2 lp., G9, 40 W
shade white	0240.89.3.W.BS	0240.86.3.W.BS	0240.89L.3.W.BS	0240.87.3.W.BS	0240.85.3.W.BS	0240.62.3.W.BS
shade purple	0240.89.3.V.BS	0240.86.3.V.BS	0240.89L.3.V.BS	0240.87.3.V.BS	0240.85.3.V.BS	0240.62.3.V.BS
shade black	0240.89.3.Bk.BS	0240.86.3.Bk.BS	0240.89L.3.Bk.BS	0240.87.3.Bk.BS	0240.85.3.Bk.BS	0240.62.3.Bk.BS



PARALUME

Frame: chrome plated Crystal: OPTIC® KOLARZ® Crystal Clear

	80 cm 50 cm / 75 - 250 cm 9 lp., G9, 40 W	60 cm 50 cm / 70 - 250 cm 6 lp., G9, 40 W	180 / 30 cm 50 cm / 57 - 300 cm 9 lp., G9, 40 W	140 / 27 cm 50 cm / 57 - 250 cm 7 lp., G9, 40 W	90 / 27 cm 50 cm / 57 - 250 cm 5 lp., G9, 40 W	36 / 46 cm 15 cm 2 lp., G9, 40 W
shade white	0240.89.5.W.KoT	0240.86.5.W.KoT	0240.89L.5.W.KoT	0240.87.5.W.KoT	0240.85.5.W.KoT	0240.62.5.W.KoT
shade purple	0240.89.5.V.KoT	0240.86.5.V.KoT	0240.89L.5.V.KoT	0240.87.5.V.KoT	0240.85.5.V.KoT	0240.62.5.V.KoT
shade black	0240.89.5.Bk.KoT	0240.86.5.Bk.KoT	0240.89L.5.Bk.KoT	0240.87.5.Bk.KoT	0240.85.5.Bk.KoT	0240.62.5.Bk.KoT

Frame: chrome plated Crystal: SPECTRA® Clear

	80 cm 50 cm / 75 - 250 cm 9 lp., G9, 40 W	60 cm 50 cm / 70 - 250 cm 6 lp., G9, 40 W	180 / 30 cm 50 cm / 57 - 300 cm 9 lp., G9, 40 W	140 / 27 cm 50 cm / 57 - 250 cm 7 lp., G9, 40 W	90 / 27 cm 50 cm / 57 - 250 cm 5 lp., G9, 40 W	36 / 46 cm 15 cm 2 lp., G9, 40 W
shade white	0240.89.5.W	0240.86.5.W	0240.89L.5.W	0240.87.5.W	0240.85.5.W	0240.62.5.W
shade purple	0240.89.5.V	0240.86.5.V	0240.89L.5.V	0240.87.5.V	0240.85.5.V	0240.62.5.V
shade black	0240.89.5.Bk	0240.86.5.Bk	0240.89L.5.Bk	0240.87.5.Bk	0240.85.5.Bk	0240.62.5.Bk

Frame: chrome plated Crystal: SWAROVSKI® Pink/Amber/Purple + SPECTRA® Clear

	80 cm 50 cm / 75 - 250 cm 9 lp., G9, 40 W	60 cm 50 cm / 70 - 250 cm 6 lp., G9, 40 W	180 / 30 cm 50 cm / 57 - 300 cm 9 lp., G9, 40 W	140 / 27 cm 50 cm / 57 - 250 cm 7 lp., G9, 40 W	90 / 27 cm 50 cm / 57 - 250 cm 5 lp., G9, 40 W	36 / 46 cm 15 cm 2 lp., G9, 40 W
shade white	0240.89.5.W.STR NEU	0240.86.5.W.STR NEU	0240.89L.5.W.STR NEU	0240.87.5.W.STR NEU	0240.85.5.W.STR NEU	0240.62.5.W.STR NEU
shade purple	0240.89.5.V.STR NEU	0240.86.5.V.STR NEU	0240.89L.5.V.STR NEU	0240.87.5.V.STR NEU	0240.85.5.V.STR NEU	0240.62.5.V.STR NEU
shade black	0240.89.5.Bk.STR NEU	0240.86.5.Bk.STR NEU	0240.89L.5.Bk.STR NEU	0240.87.5.Bk.STR NEU	0240.85.5.Bk.STR NEU	0240.62.5.Bk.STR NEU

Frame: chrome plated Crystal: SWAROVSKI® Black + SPECTRA® Clear

	80 cm 50 cm / 75 - 250 cm 9 lp., G9, 40 W	60 cm 50 cm / 70 - 250 cm 6 lp., G9, 40 W	180 / 30 cm 50 cm / 57 - 300 cm 9 lp., G9, 40 W	140 / 27 cm 50 cm / 57 - 250 cm 7 lp., G9, 40 W	90 / 27 cm 50 cm / 57 - 250 cm 5 lp., G9, 40 W	36 / 46 cm 15 cm 2 lp., G9, 40 W
shade white	0240.89.5.W.STR JET	0240.86.5.W.STR JET	0240.89L.5.W.STR JET	0240.87.5.W.STR JET	0240.85.5.W.STR JET	0240.62.5.W.STR JET
shade purple	0240.89.5.V.STR JET	0240.86.5.V.STR JET	0240.89L.5.V.STR JET	0240.87.5.V.STR JET	0240.85.5.V.STR JET	0240.62.5.V.STR JET
shade black	0240.89.5.Bk.STR JET	0240.86.5.Bk.STR JET	0240.89L.5.Bk.STR JET	0240.87.5.Bk.STR JET	0240.85.5.Bk.STR JET	0240.62.5.Bk.STR JET

Frame: chrome plated Crystal: SWAROVSKI® Blue/Bronze shade + SPECTRA® Clear

	80 cm 50 cm / 75 - 250 cm 9 lp., G9, 40 W	60 cm 50 cm / 70 - 250 cm 6 lp., G9, 40 W	180 / 30 cm 50 cm / 57 - 300 cm 9 lp., G9, 40 W	140 / 27 cm 50 cm / 57 - 250 cm 7 lp., G9, 40 W	90 / 27 cm 50 cm / 57 - 250 cm 5 lp., G9, 40 W	36 / 46 cm 15 cm 2 lp., G9, 40 W
shade white	0240.89.5.W.BS	0240.86.5.W.BS	0240.89L.5.W.BS	0240.87.5.W.BS	0240.85.5.W.BS	0240.62.5.W.BS
shade purple	0240.89.5.V.BS	0240.86.5.V.BS	0240.89L.5.V.BS	0240.87.5.V.BS	0240.85.5.V.BS	0240.62.5.V.BS
shade black	0240.89.5.Bk.BS	0240.86.5.Bk.BS	0240.89L.5.Bk.BS	0240.87.5.Bk.BS	0240.85.5.Bk.BS	0240.62.5.Bk.BS

Rosette

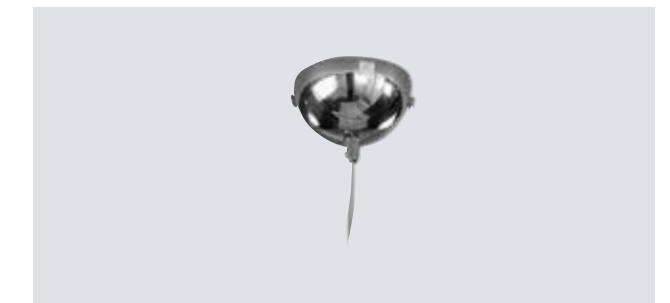
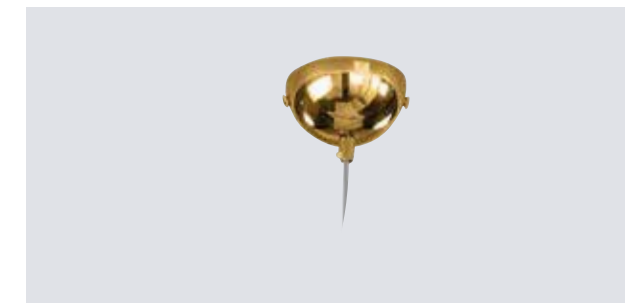

GIOIOSA



Design by Kolarz Studio



FLO.1097/580.03.T-BL



Funkelnde Kristalle treffen feinsten Organza und 24 Karat Gold oder Chrom: Unsere Gioiosa verleiht Wohn- und Schlafräumen Eleganz und Glamour.

Sparkling crystals meet finest organza and 24 carat gold or chrome: Our Gioiosa adds timeless elegance and glamour to living rooms and bedrooms.



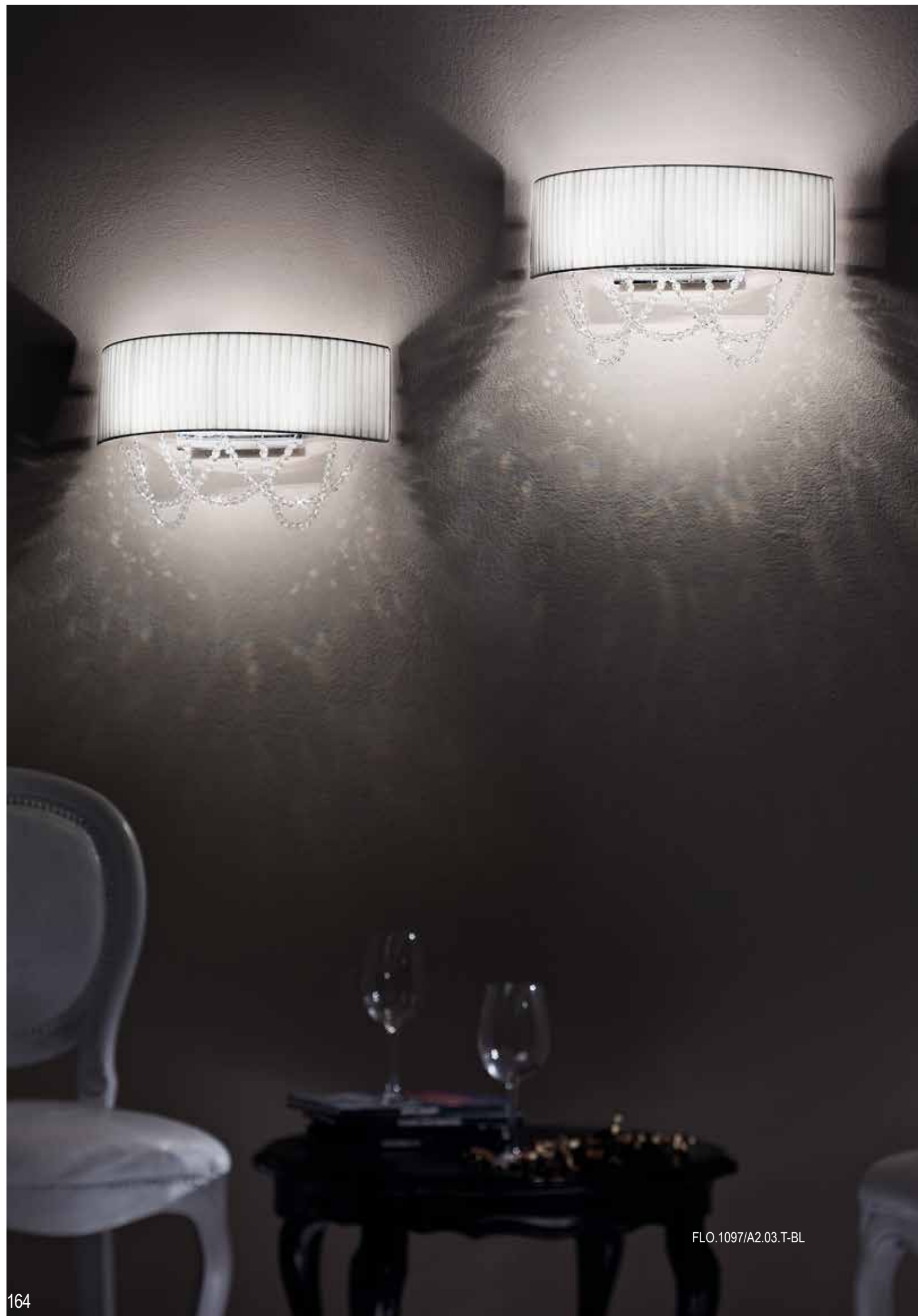

FLO.1097/A2.03.T-BL



GIOIOSA

■ Frame: 24 carat gold plated Crystal: PURE® KOLARZ® Crystal Clear

	⌀ 80 cm max. 170 cm 12 lp., G9, 40W	⌀ 60 cm max. 160 cm 6 lp., G9, 40W	⌀ 80 cm 45 cm 12 lp., G9, 40W	⌀ 60 cm 40 cm 6 lp., G9, 40W	40/20 cm 10 cm 2 lp., G9, 40W
	shade white FLO.1097/S80.04.T-WH	FLO.1097/S60.04.T-WH	FLO.1097/PL80.04.T-WH	FLO.1097/PL60.04.T-WH	FLO.1097/A2.04.T-WH
	shade black FLO.1097/S80.04.T-BL	FLO.1097/S60.04.T-BL	FLO.1097/PL80.04.T-BL	FLO.1097/PL60.04.T-BL	FLO.1097/A2.04.T-BL

■ Frame: chrome plated Crystal: PURE® KOLARZ® Crystal Clear

	⌀ 80 cm max. 170 cm 12 lp., G9, 40W	⌀ 60 cm max. 160 cm 6 lp., G9, 40W	⌀ 80 cm 45 cm 12 lp., G9, 40W	⌀ 60 cm 40 cm 6 lp., G9, 40W	40/20 cm 10 cm 2 lp., G9, 40W
	shade white FLO.1097/S80.03.T-WH	FLO.1097/S60.03.T-WH	FLO.1097/PL80.03.T-WH	FLO.1097/PL60.03.T-WH	FLO.1097/A2.03.T-WH
	shade black FLO.1097/S80.03.T-BL	FLO.1097/S60.03.T-BL	FLO.1097/PL80.03.T-BL	FLO.1097/PL60.03.T-BL	FLO.1097/A2.03.T-BL

■ Frame: 24 carat gold plated Crystal: OPTIC® KOLARZ® Crystal Clear

	⌀ 80 cm max. 170 cm 12 lp., G9, 40W	⌀ 60 cm max. 160 cm 6 lp., G9, 40W	⌀ 80 cm 45 cm 12 lp., G9, 40W	⌀ 60 cm 40 cm 6 lp., G9, 40W	40/20 cm 10 cm 2 lp., G9, 40W
	shade white 5020.31232.130/po10	5020.30630.130/po10	5020.11232.130/po10	5020.10630.130/po10	5020.60230.130/po10
	shade black 5020.31232.130/po90	5020.30630.130/po90	5020.11232.130/po90	5020.10630.130/po90	5020.60230.130/po90

■ Frame: chrome plated Crystal: OPTIC® KOLARZ® Crystal Clear

	⌀ 80 cm max. 170 cm 12 lp., G9, 40W	⌀ 60 cm max. 160 cm 6 lp., G9, 40W	⌀ 80 cm 45 cm 12 lp., G9, 40W	⌀ 60 cm 40 cm 6 lp., G9, 40W	40/20 cm 10 cm 2 lp., G9, 40W
	shade white 5020.31252.130/po10	5020.30650.130/po10	5020.11252.130/po10	5020.10650.130/po10	5020.60250.130/po10
	shade black 5020.31252.130/po90	5020.30650.130/po90	5020.11252.130/po90	5020.10650.130/po90	5020.60250.130/po90



Also available with the decors of the Masterpieces.



NOBILE

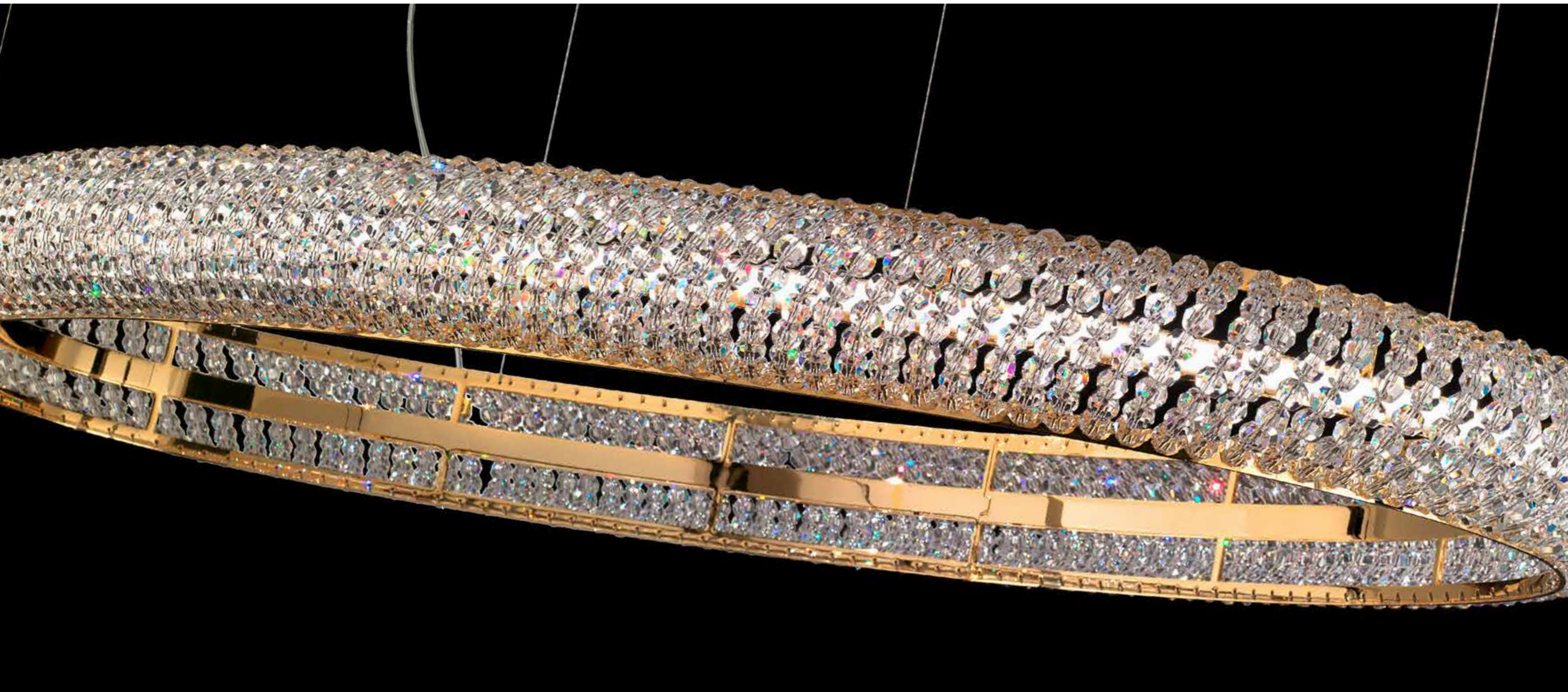

Design by Kolarz Studio



6004.30230.530

Runde Sache: mit funkelnden Kristallen besetzte Ringe aus Licht auf 24-Karat-vergoldeten oder in Dark Chrome gehaltenen Metallrahmen. Nobile verleiht jedem Setting Style und Glamour und erstrahlt flexibel montierbar als Solo-Piece oder im Mix von zwei oder mehr Ringen.

Perfection all round: brilliant rings of sparkling crystals on 24-carat gold-plated or dark chrome finished metal frames. Nobile adds style and glamour to any setting and shines brightly in various mounting options, either as a solo piece or in a mix of two or more lights.



Round Shape

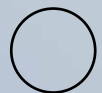

Projekt mit 2 Elementen 6004.30230.530 / 6004.30130.530
Project with 2 elements 6004.30230.530 / 6004.30130.530



Round Shape



6004.30259.530



Round Shape



6004.30130.530



Oval Shape



6004.30359.530

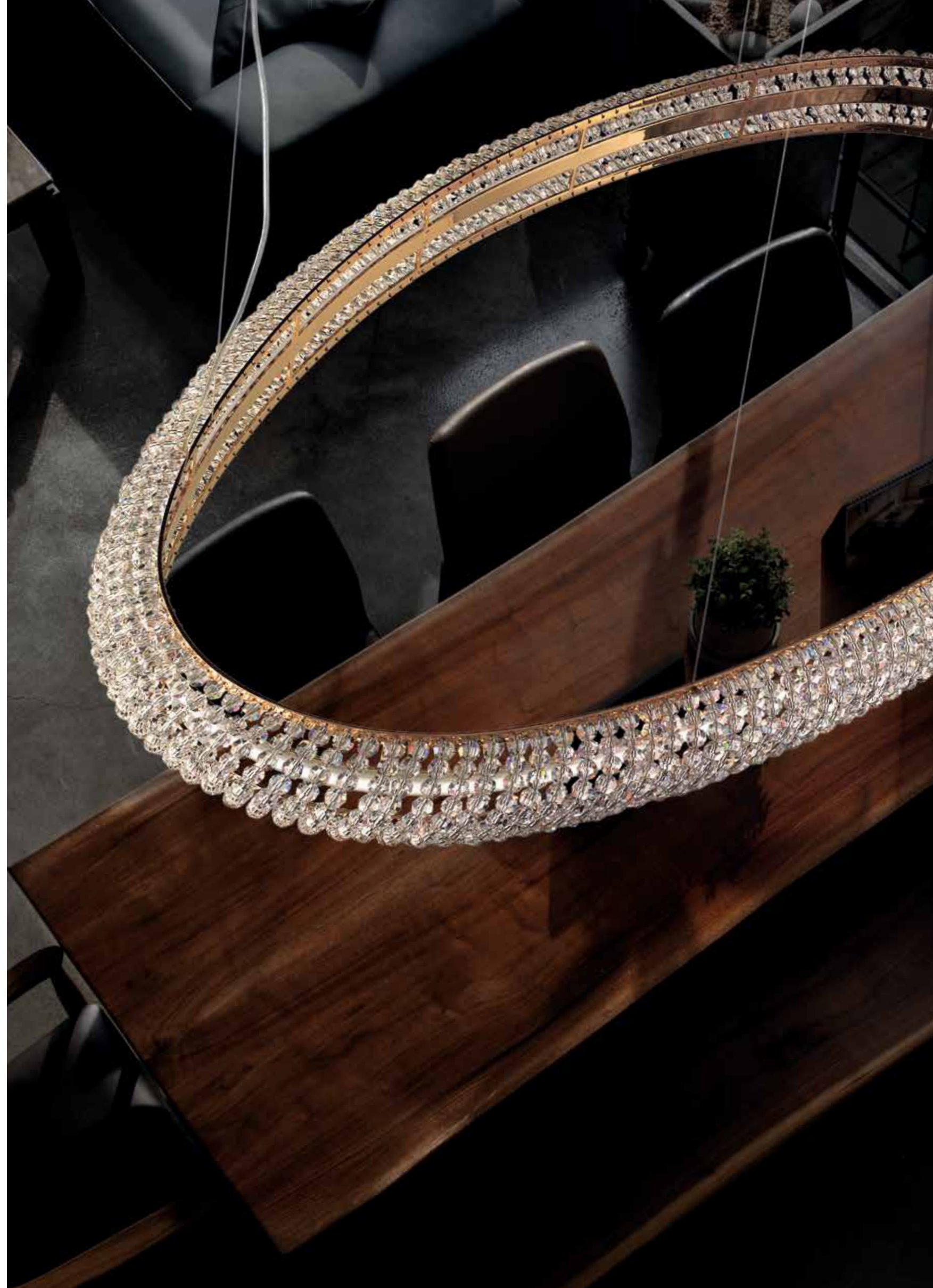

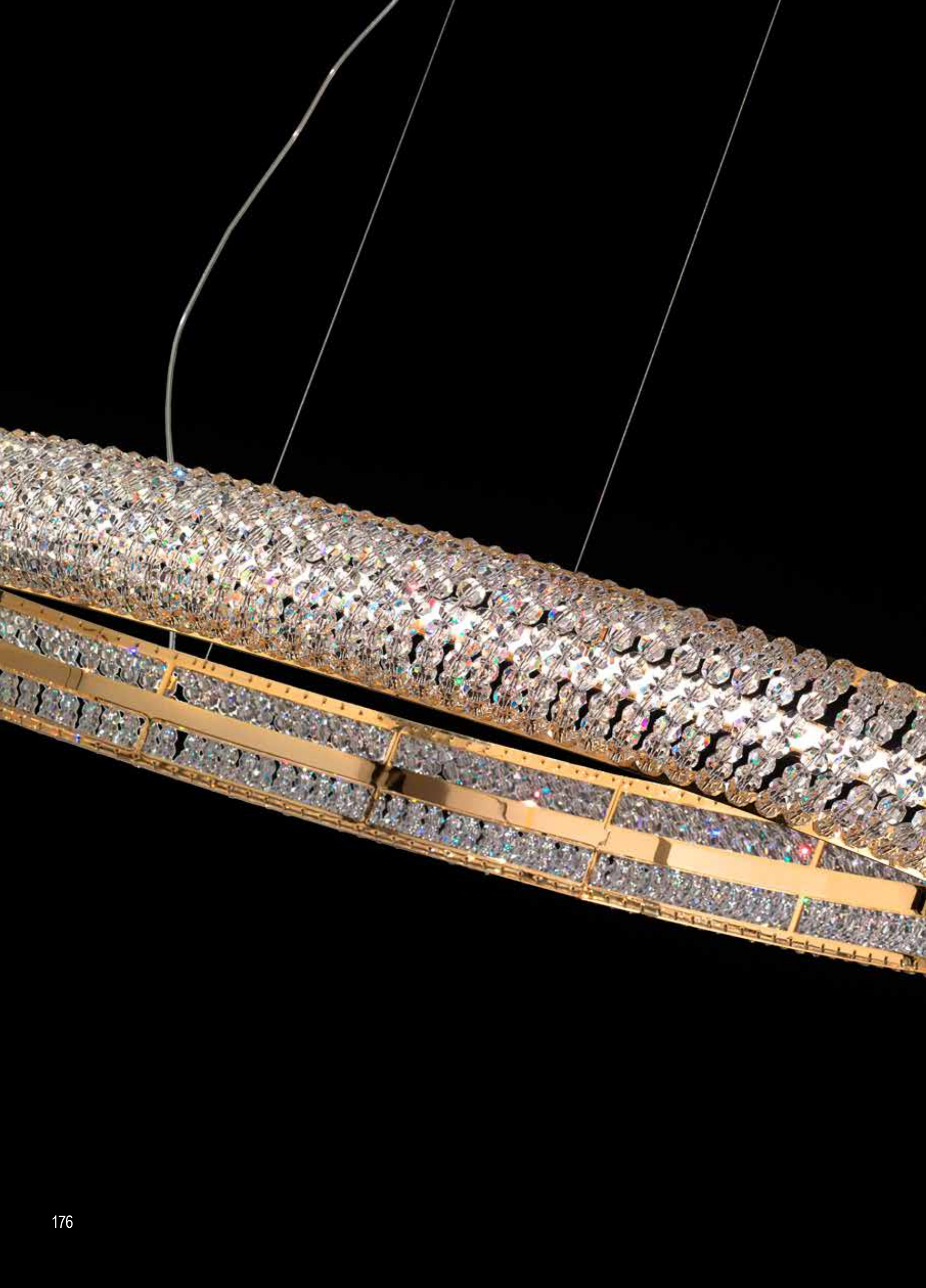

NOBILE

Crystal: PURE® KOLARZ® Crystal Clear

	1) LED	1) LED	1) LED	LED
	120 / 60 cm 10 cm / max. 210 cm LED STRIP, dimmable 58 W, 7200 lm, 2700 K	120 / 60 cm 10 cm / max. 210 cm LED STRIP, dimmable 58 W, 7200 lm, 2700 K	120 / 60 cm 10 cm / max. 210 cm LED STRIP, dimmable 58 W, 7200 lm, 2700 K	120 / 60 cm 10 cm / max. 210 cm LED STRIP, dimmable 58 W, 7200 lm, 2700 K
gold plated	6004.30330.530	6004.30230.530	6004.30130.530	6004.60130.530
dark chrome	6004.30359.530	6004.30259.530	6004.30159.530	6004.60159.530

KOLARZ® CRYSTAL DIFFUSER



Rosette



1) • PUSH
 • DALI
 • 0-10 V
 • LINEAR 100KΩ

1) optional DIM TRIAC

CARLA



Design by Kolarz Studio



0256.315.3.ssT

Strahlende Schönheit: Carla, ein moderner Kristall-Luster in stylish-puristischem Design, schafft mondänes, atmosphärisches Ambiente. Von Hand bestückte Ringe aus funkelnden Kristallen zeigen rundum Perfektion.

Brilliant beauty: Carla, a contemporary crystal chandelier in a stylish sleek design, creates sophisticated atmospheric ambiance. Handcrafted rings of sparkling crystals show perfection all round.



0256.35.3.KpT



0256.15L.3.KpT



0256.13L.5.KpT



0256.15S.3.SsT



0256.11.5.SsT



0256.15S.5.SsT



0256.11.3.SsT



0256.62.3.KpT



0324.11.3.KpT



0324.11.5.KpT

CARLA

Frame: 24 carat gold plated

	⌀ 110 cm 32 cm / 50 - 190 cm 15 lp., G9, 25 W	⌀ 55 cm 15 cm / 30 - 190 cm 5 lp., G9, 25 W	⌀ 55 cm 16 cm 5 lp., G9, 25 W	⌀ 55 cm 12 cm 5 lp., G9, 25 W	⌀ 35 cm 16 cm 3 lp., G9, 25 W	⌀ 35 cm 12 cm 3 lp., G9, 25 W	
	SWAROVSKI® clear	0256.315.3.SsT	0256.35.3.SsT	0256.15L3.SsT	0256.15S.3.SsT	0256.13L3.SsT	0256.13S.3.SsT
	PURE® KOLARZ® clear	0256.315.3.KpT	0256.35.3.KpT	0256.15L3.KpT	0256.15S.3.KpT	0256.13L3.KpT	0256.13S.3.KpT
	⌀ 17 cm 15 cm 1 lp., G9, 40 W	⌀ 11 cm 20 cm 1 lp., G9, 40 W	7 / 41 cm 14 cm 2 lp., G9, 25 W				
	SWAROVSKI® clear	0256.11.3.SsT	-	0256.62.3.SsT			
	PURE® KOLARZ® clear	0256.11.3.KpT	0324.11.3.KpT	0256.62.3.KpT			

Frame: chrome plated

	⌀ 110 cm 32 cm / 50 - 190 cm 15 lp., G9, 25 W	⌀ 55 cm 15 cm / 30 - 190 cm 5 lp., G9, 25 W	⌀ 55 cm 16 cm 5 lp., G9, 25 W	⌀ 55 cm 12 cm 5 lp., G9, 25 W	⌀ 35 cm 16 cm 3 lp., G9, 25 W	⌀ 35 cm 12 cm 3 lp., G9, 25 W	
	SWAROVSKI® clear	0256.315.5.SsT	0256.35.5.SsT	0256.15L5.SsT	0256.15S.5.SsT	0256.13L5.SsT	0256.13S.5.SsT
	PURE® KOLARZ® clear	0256.315.5.KpT	0256.35.5.KpT	0256.15L5.KpT	0256.15S.5.KpT	0256.13L5.KpT	0256.13S.5.KpT
	⌀ 17 cm 15 cm 1 lp., G9, 40 W	⌀ 11 cm 20 cm 1 lp., G9, 40 W	7 / 41 cm 14 cm 2 lp., G9, 25 W				
	SWAROVSKI® clear	0256.11.5.SsT	-	0256.62.5.SsT			
	PURE® KOLARZ® clear	0256.11.5.KpT	0324.11.5.KpT	0256.62.5.KpT			



DELPHI



Design by Kolarz Studio

Pur und schlicht oder mit dekorativer Handmalerei in verschiedenen Farben und Designs, setzt unser Deckenfluter Delphi ein Statement und verleiht jedem Raum spannende Lichteffekte.



Pure and sleek or with decorative handpainting in various colours and designs, our Delphi up-lighter makes a statement and adds exciting light effects to any room.







DELPHI

■ Frame: 24 carat gold plated

	1)	2)	LED
			
	26 / 60 cm 185 cm 1 x R7s, max. 200 W + 1 x R7s max. 300 W touch dimmer	26 / 60 cm 185 cm 4 lp., 13 W 7696 lm, 2700 K touch dimmer	
glass transparent	0252.41.3.Ki.Au	2252.41.3.Ki.Au	

■ Frame: chrome plated

	1)	2)	LED
			
	26 / 60 cm 185 cm 1 x R7s, max. 200 W + 1 x R7s max. 300 W touch dimmer	26 / 60 cm 185 cm 4 lp., 13 W 7696 lm, 2700 K touch dimmer	
glass transparent	0252.41.5.Ki.Ag	2252.41.5.Ki.Ag	



Also available with the decors of the Masterpieces.

0252.41.5



KOLARZ reserves itself the right to introduce changes to its own models without prior notice.

KOLARZ is not liable for injuries or damage due to the incorrect installation of its products.

The details given here are only intended as a guidance.

Printing errors excepted.

Layout, photo-editing, project and photo:
FISHEYE COMUNICAZIONE
fisheyecomunicazione@gmail.com



With Compliments